

ABB MACHINERY DRIVES

ACS380 drives

Hardware manual



List of related manuals

Drive manuals and guides

ACS380 drives hardware manual

ACS380 quick installation and start-up guide

ACS380 user interface guide

ACS380 firmware manual

Code (English)

[3AXD50000029274](#)

[3AXD50000018553](#)

[3AXD50000022224](#)

[3AXD50000029275](#)

Option manuals and guides

ACS-AP-x Assistant control panel user's manual

[3AUA0000085685](#)

Tool and maintenance manuals

Drive composer PC tool user's manual

[3AUA0000094606](#)

Converter module capacitor reforming instructions

[3BFE64059629](#)

You can find manuals and other product documents in PDF format on the Internet. See section Document library on the Internet on the inside of the back cover. For manuals not available in the Document library, contact your local ABB representative.

The code below opens an online listing of the manuals applicable to the product:



[ACS380 manuals](#)

Hardware manual

ACS380 drives

Table of contents



1. Safety instructions



4. Mechanical installation



6. Electrical installation



Table of contents

1. Safety instructions

Contents of this chapter	13
Use of warnings and notes in this manual	13
General safety in installation, start-up and maintenance	14
Electrical safety in installation, start-up and maintenance	15
Precautions before electrical work	15
Additional instructions and notes	16
Grounding	17
Additional instructions for permanent magnet motor drives	18
Safety in installation, start-up and maintenance	18
General safety in operation	19

2. Introduction to the manual

Contents of this chapter	21
Applicability	21
Target audience	21
Purpose of the manual	21
Contents of this manual	22
Related documents	22
Categorization by frame (size)	22
Quick installation and commissioning flowchart	24



3. Hardware description

Contents of this chapter	27
General description	27
Product variants	27
Hardware overview	28
Control connections	29
Standard variant (I/O and Modbus) (ACS380-04xS)	29
Configured variant (ACS380-04xC)	30
Base variant (ACS380-04xN)	31
Side-mounted options	32
Control panel options	32
PC connection	32
Drive labels	33
Model information label	33
Type designation label	34
Type designation key	35
Operation principle	37
Control panel	38
Home view	39
Message view	40
Options view	40

6 Table of contents

Menu	40
------------	----

4. Mechanical installation

Contents of this chapter	41
Examining the installation site	42
Required tools	43
Unpacking the delivery	43
Installing the drive	44
To install the drive with screws	44
To install the drive to a DIN installation rail	45

5. Planning the electrical installation

Contents of this chapter	47
Selecting the supply disconnecting device	47
European Union	47
Other regions	48
Checking the compatibility of the motor and drive	48
Selecting the power cables	48
Typical power cable sizes	49
Recommended power cable types	51
Power cable types for limited use	51
Not allowed power cable types	51
Motor cable shield	52
Additional US requirements	52
Selecting the control cables	54
Shielding	54
Signals in separate cables	54
Signals that can be run in the same cable	54
Relay cable	54
Drive composer PC tool cable	54
Routing the cables	55
Separate control cable ducts	56
Continuous motor cable shield or conduit	56
Implementing short-circuit protection	56
Protecting the drive and input power cable in short-circuits	56
Protecting the motor and motor cable in short-circuits	56
Implementing thermal overload protection	57
Protecting the drive, and the input power and motor cables against thermal overload	57
Protecting the motor against thermal overload	57
Protecting the drive against ground faults	57
Residual current device compatibility	57
Implementing the emergency stop function	57
Implementing the Safe torque off function	58
Using a safety switch between the drive and motor	58
Using a contactor between the drive and motor	58
Protecting the contacts of relay outputs	59



6. Electrical installation

Contents of this chapter	61
Warnings	61
Required tools	61
Measuring insulation	62
Drive	62
Input power cable	62
Motor and motor cable	62
Brake resistor assembly	62
Compatibility with IT (ungrounded) and corner-grounded TN systems	63
EMC filter	63
EMC filter disconnection	63
Ground-to-phase varistor	64
Connecting the power cables	65
Connection diagram	65
Connection procedure	66
Connecting the control cables	68
Default I/O connection diagram (ABB standard macro)	69
Fieldbus connection diagram	72
Control cable connection procedure	73
Auxiliary voltage connection	74
Option modules	75
To install a front option	75
To remove a front option	76
To install a side option	76
To remove a side option	76



7. Installation checklist

Contents of this chapter	77
Warnings	77
Checklist	77

8. Maintenance

Contents of this chapter	79
Maintenance intervals	80
Cleaning the heat sink	81
Replacing the cooling fans	82
To replace the cooling fan for frames R1–R3	82
To replace the cooling fan for frame R4	83
Servicing the capacitors	85
Capacitor reforming	85

9. Technical data

Contents of this chapter	87
Ratings	88
IEC ratings	88
NEMA ratings	89
Definitions	89

8 Table of contents

Sizing	89
Derating	90
Surrounding air temperature derating, IP20	90
Switching frequency derating	91
Altitude derating	92
Fuses (IEC)	93
gG fuses	93
UL fuses	95
gR fuses	96
Alternate short-circuit protection	97
Miniature circuit breakers (IEC environment)	97
Self-protected combination manual controller – Type E	
USA (UL) environment	98
Dimensions and weights	100
Free space requirements	101
Losses, cooling data and noise	101
Terminal data for the power cables	103
IEC	103
Terminal data for the control cables	104
External EMC filters	105
Electric power network specification	106
Motor cable length	107
Motor connection data	107
Control connection data	109
Brake resistor connection	110
Efficiency	110
Degrees of protection	110
Ambient conditions	111
Materials	112
Applicable standards	112
CE marking	113
Compliance with the European Low Voltage Directive	113
Compliance with the European EMC Directive	113
Compliance with the European RoHS Directive	113
Compliance with the European WEEE Directive	113
Compliance with the European Machinery Directive	114
Compliance with EN 61800-3:2004 + A1:2012	115
Definitions	115
Category C1	115
Category C2	115
Category C3	116
Category C4	117
UL marking	118
UL checklist	118
RCM marking	118
EAC marking	118
China RoHS marking	119
Disclaimers	119
Generic disclaimer	119
Cyber security disclaimer	119



10. Dimension drawings

Frame R0 (1-phase 230 V)	122
Frame R0 (400 V)	123
Frame R1 (230 V)	124
Frame R1 (3-phase 230 V and 3-phase 400 V)	125
Frame R2 (230 V)	126
Frame R2 (400 V)	127
Frame R3 (400 V)	128
Frame R4 (400 V)	129

11. Resistor braking

Contents of this chapter	131
Operation principle and hardware description	131
Selecting the brake resistor	131
Reference brake resistors	133
Selecting and routing the brake resistor cables	134
Minimizing electromagnetic interference	134
Maximum cable length	134
EMC compliance of the complete installation	134
Placing the brake resistor	134
Protecting the system in brake circuit fault situations	135
Protecting the system in cable and brake resistor short-circuit situations	135
Protecting the system against thermal overload	135
Mechanical installation	135
Electrical installation	136
Checking the insulation of the assembly	136
Connection diagram	136
Connection procedure	136
Start-up	137



12. Safe torque off function

Contents of this chapter	139
Description	139
Compliance with the European Machinery Directive	140
Connection principle	141
Connection with internal +24 V DC power supply	141
Connection with external +24 V DC power supply	141
Wiring examples	142
Activation switch	142
Cable types and lengths	143
Grounding of protective shields	143
Operation principle	143
Start-up including acceptance test	144
Competence	144
Acceptance test reports	144
Acceptance test procedure	145
Use	146
Maintenance	148

Competence	148
Fault tracing	148
Safety data	150
Abbreviations	152
Declaration of conformity	152

13. BTAC-02 pulse encoder interface module

Contents of this chapter	153
Safety instructions	153
Hardware description	154
Product overview	154
Layout	154
Mechanical installation	155
Electrical installation	155
Wiring – General	155
Wiring – Encoder power supply interface	157
Wiring – Encoder	158
Start-up	165
Feedback selection	165
Encoder adapter settings	166
These parameters display the configuration of the encoder interface modules. Encoder configuration	166
Diagnostics	167
Technical data	168
Encoder interface	168
Back-up power supply for the drive	168
Internal connectors	168
Dimensions	169



14. BREL-01 relay output extension module

Contents of this chapter	171
Safety instructions	171
Hardware description	172
Product overview	172
Layout	172
Mechanical installation	173
Electrical installation	173
Terminal designations	173
Wiring	173
Apply power	173
Start-up	174
Configuration parameters	174
Technical data	176
External connectors	176
Internal connectors	176
Dimensions	176

15. BAPO-01 power extension module

Contents of this chapter	177
Safety instructions	177
Hardware description	178
Product overview	178
Layout	178
Mechanical installation	179
Electrical installation	179
Start-up	179
Technical data	180
Voltage and current rating for the auxiliary power supply	180
Power loss	180
Dimensions	180

16. BIO-01 I/O extension module

Contents of this chapter	181
Safety instructions	181
Hardware description	182
Product overview	182
Layout	182
Mechanical installation	183
Electrical installation	183
Start-up	183
Technical data	184
Control connection data	184
Dimensions	184

**Further information**



1

Safety instructions



Contents of this chapter

This chapter contains the safety instructions which you must obey when you install and operate the drive and do maintenance on the drive. If you ignore the safety instructions, injury, death or damage can occur.

Use of warnings and notes in this manual

Warnings tell you about conditions which can cause injury or death, or damage to the equipment. They also tell you how to prevent the danger. Notes draw attention to a particular condition or fact, or give information on a subject.

The manual uses these warning symbols:

	Electricity warning tells you about hazards from electricity which can cause injury or death, or damage to the equipment.
	General warning tells you about conditions, other than those caused by electricity, which can cause injury or death, or damage to the equipment.
	Electrostatic sensitive devices warning tells you about the risk of electrostatic discharge which can cause damage to the equipment.



General safety in installation, start-up and maintenance

These instructions are for all personnel that install the drive and do maintenance work on it.



WARNING! Obey these instructions. If you ignore them, injury or death, or damage to the equipment can occur.

- Handle the drive carefully.
- Use safety shoes with a metal toe cap.
- Keep the drive in its package or protect it otherwise from dust and burr from drilling and grinding until you install it.
- Vacuum clean the area below the drive before the start-up to prevent the drive cooling fan from drawing the dust inside the drive.
- Protect also the installed drive against dust and burr. Electrically conductive debris inside the drive may cause damage or malfunction.
- Do not cover the air inlet and outlet when the drive runs.
- Make sure that there is sufficient cooling.
- Before you connect voltage to the drive, make sure that the drive covers are on. Keep the covers on during operation.
- Before you adjust the drive operation limits, make sure that the motor and all driven equipment can operate throughout the set operation limits.
- Before you activate automatic fault reset functions of the drive control program, make sure that no dangerous situations can occur. These functions reset the drive automatically and continue operation after a fault. If these functions are activated, the installation must be clearly marked as defined in IEC/EN 61800-5-1, subclause 6.5.3, for example, “THIS MACHINE STARTS AUTOMATICALLY”.
- The maximum number of drive power-ups is two per minute. Too frequent power-ups can damage the charging circuit of the DC capacitors. The maximum total number of chargings is 15000.
- If you have connected safety circuits to the drive (for example, emergency stop and Safe torque off), validate them at the start up.

Note:

- If you select an external source for start command and it is on, the drive will start immediately after a fault reset, unless you configure the drive for pulse start.
 - When the control location is not set to local, the stop key on the control panel does not stop the drive.
 - Drives can be repaired only by an authorized person.
-

Electrical safety in installation, start-up and maintenance

■ Precautions before electrical work

These warnings are for all personnel who do work on the drive, motor cable or motor.



WARNING! Obey these instructions. If you ignore them, injury or death, or damage to the equipment can occur. If you are not a qualified electrician, do not do electrical installation or maintenance work. Do these steps before you begin any installation or maintenance work.

1. Clearly identify the work location.
 2. Disconnect all possible voltage sources.
 - Open the main disconnecter at the power supply of the drive.
 - Make sure that reconnection is not possible. Lock the disconnecter to open position and attach a warning notice to it.
 - Disconnect any external power sources from the control circuits before you do work on the control cables.
 - After you disconnect the drive, always wait for 5 minutes to let the intermediate circuit capacitors discharge before you continue.
 3. Protect any other energized parts in the work location against contact.
 4. Take special precautions when close to bare conductors.
 5. Measure that the installation is de-energized.
 - Use a multimeter with an impedance of at least 1 Mohm.
 - Make sure that the voltage between the drive input power terminals (L1, L2, L3) and the grounding terminal (PE) is close to 0 V.
 - Make sure that the voltage between the drive DC terminals (UDC+ and UDC-) and the grounding terminal (PE) is close to 0 V.
 6. Install temporary grounding as required by the local regulations.
 7. Ask for a permit to work from the person in control of the electrical installation work.
-



■ Additional instructions and notes



WARNING! Obey these instructions. If you ignore them, injury or death, or damage to the equipment can occur.

- If you install the drive on an IT system (an ungrounded power system or a high-resistance-grounded [over 30 ohms] power system), disconnect the internal EMC filter; otherwise the system will be connected to ground potential through the EMC filter capacitors. This can cause danger or damage the drive.

Note: Disconnecting the internal EMC filter increases the conducted emission and reduces the drive EMC compatibility considerably.

- If you connect the drive to an IT system (an ungrounded power system or a high-resistance-grounded [over 30 ohms] power system), disconnect the varistor from ground. Failure to do so can cause damage to the varistor circuit.
- If you install the drive on a corner-grounded TN system, disconnect the internal EMC filter; otherwise the system will be connected to ground potential through the EMC filter capacitors. This will damage the drive.

Note: Disconnecting the internal EMC filter increases the conducted emission and reduces the drive EMC compatibility considerably.

- Use all ELV (extra low voltage) circuits connected to the drive only within a zone of equipotential bonding, that is, within a zone where all simultaneously accessible conductive parts are electrically connected to prevent hazardous voltages appearing between them. You can accomplish this by a proper factory grounding, that is, make sure that all simultaneously accessible conductive parts are grounded to the protective earth (PE) bus of the building.
- Do not do insulation or voltage withstand tests on the drive.

Note:

- The motor cable terminals of the drive are at a dangerous voltage when the input power is on, regardless of whether the motor is running or not.
 - The DC and brake resistor terminals (UDC+, UDC-, R+ and R-) are at a dangerous voltage.
 - External wiring can supply dangerous voltages to the terminals of relay outputs.
 - The Safe torque off function does not remove the voltage from the main and auxiliary circuits. The function is not effective against deliberate sabotage or misuse.
-



WARNING! Use a grounding wrist band when you handle the printed circuit boards. Do not touch the boards unnecessarily. The components on the boards are sensitive to electrostatic discharge.

■ Grounding

These instructions are for all personnel who are responsible for the electrical installation, including the grounding of the drive.



WARNING! Obey these instructions. If you ignore them, injury or death, or equipment malfunction can occur, and electromagnetic interference can increase.

- If you are not a qualified electrician, do not do grounding work.
- Always ground the drive, the motor and adjoining equipment to the protective earth (PE) bus of the power supply. This is necessary for the personnel safety. Proper grounding also reduces electromagnetic emission and interference.
- In a multiple-drive installation, connect each drive separately to the protective earth (PE) bus of the power supply.
- Make sure that the conductivity of the protective earth (PE) conductors is sufficient. Refer to [Selecting the power cables](#) on page 48. Obey the local regulations.
- Connect the power cable shields to the protective earth (PE) terminals of the drive.
- Make a 360° grounding of the power and control cable shields at the cable entries to suppress electromagnetic disturbances.



Note:

- You can use power cable shields as grounding conductors only when their conductivity is sufficient.
- Standard IEC/EN 61800-5-1 (section 4.3.5.5.2.) requires that as the normal touch current of the drive is higher than 3.5 mA AC or 10 mA DC, you must use a fixed protective earth (PE) connection. In addition,
 - install a second protective earth conductor of the same cross-sectional area as the original protective earthing conductor,
 or
 - install a protective earth conductor with a cross-section of at least 10 mm² Cu or 16 mm² Al,
 or
 - install a device which automatically disconnects the supply if the protective earth conductor breaks.

Additional instructions for permanent magnet motor drives

■ Safety in installation, start-up and maintenance

These are additional warnings concerning permanent magnet motor drives. The other safety instructions in this chapter are also valid.



WARNING! Obey these instructions. If you ignore them, injury or death and damage to the equipment can occur.

- Do not work on a drive when a rotating permanent magnet motor is connected to it. A rotating permanent magnet motor energizes the drive including its input power terminals.

Before installation, start-up and maintenance work on the drive:

- Stop the motor.
- Disconnect the motor from the drive with a safety switch or by other means.
- If you cannot disconnect the motor, make sure that the motor cannot rotate during work. Make sure that no other system, like hydraulic crawling drives, can rotate the motor directly or through any mechanical connection like felt, nip, rope, etc.
- Measure that the installation is de-energized.
 - Use a multimeter with an impedance of at least 1 Mohm.
 - Make sure that the voltage between the drive output terminals (T1/U, T2/V, T3/W) and the grounding (PE) busbar is close to 0 V.
 - Make sure that the voltage between the drive input power terminals (L1, L2, L3) and the grounding (PE) busbar is close to 0 V.
 - Make sure that the voltage between the drive DC terminals (UDC+, UDC-) and the grounding (PE) terminal is close to 0 V.
- Install temporary grounding to the drive output terminals (T1/U, T2/V, T3/W). Connect the output terminals together as well as to the PE.

Start-up and operation:

- Make sure that the operator cannot run the motor over the rated speed. Motor overspeed causes overvoltage that can damage or explode the capacitors in the intermediate circuit of the drive.
-



General safety in operation

These instructions are for all personnel that operate the drive.



WARNING! Obey these instructions. If you ignore them, injury or death, or damage to the equipment can occur.

- Do not control the motor with the disconnecter at the drive power supply. Use the control panel start and stop keys or the start/stop commands from an external control device connected through the I/O or fieldbus interface.
- Give a stop command to the drive before you reset a fault. If you have an external source for the start command and the start is on, the drive will start immediately after the fault reset, unless you configure the drive for pulse start. See the firmware manual.
- Before you activate automatic fault reset functions of the drive control program, make sure that no dangerous situations can occur. These functions reset the drive automatically and continue operation after a fault.

Note: When the control location is not set to Local, the stop key on the control panel will not stop the drive.





A large, light blue square with rounded corners, centered on the page. Inside the square is a large, bold, black number '2'.

Introduction to the manual

Contents of this chapter

The chapter describes the applicability, target audience and purpose of this manual. It describes the contents of this manual. The chapter also has a flowchart for the delivery, installation and commissioning of the drive.

Applicability

The manual applies to ACS380 drives. The 3-phase 230V device has limited availability. Please contact your local ABB representative for information on availability.

Target audience

The reader must know the fundamentals of electricity, wiring, electrical components and electrical schematic symbols.

Purpose of the manual

This manual has the information needed to plan the installation, and install, commission and service the drive.

Contents of this manual

- [Safety instructions](#) (on page 13) gives the safety instructions that you must obey when you install, commission, operate and service the drive.
- [Introduction to the manual](#) (on page 21) describes the applicability, target audience, purpose and contents of this manual.
- [Hardware description](#) (on page 27) describes the operation principle, layout, power connections and control interfaces, type designation information.
- [Mechanical installation](#) (on page 41) describes how to examine the installation site, unpack, examine the delivery and install the drive mechanically.
- [Planning the electrical installation](#) (on page 47) describes how to plan the electrical installation of the drive.
- [Electrical installation](#) (on page 61) describes how to measure the insulation of the assembly and the compatibility with IT (ungrounded) and corner-grounded TN systems. It shows how to connect the power and control cables, install optional modules and connect a PC.
- [Installation checklist](#) (on page 77) contains a checklist for the mechanical and electrical installation of the drive before start-up.
- [Maintenance](#) (on page 79) contains the preventive maintenance instructions and LED indicator descriptions.
- [Technical data](#) (on page 87) contains the technical specifications of the drive.
- [Dimension drawings](#) (on page 121) shows the dimension drawings of the drive.
- [Resistor braking](#) (on page 131) tells you how to select the brake resistor.
- [Safe torque off function](#) (on page 139) describes the STO features, installation and technical data.
- [BTAC-02 pulse encoder interface module](#) (on page 153) describes the optional BTAC-02 module.
- [BREL-01 relay output extension module](#) (on page 171) describes the optional BREL-01 module.
- [BAPO-01 power extension module](#) (on page 177) describes the optional BAPO-01 module.
- [BIO-01 I/O extension module](#) (on page 181) describes the optional BIO-01 I/O extension module.

Related documents

Refer to [List of related manuals](#) on page 2 (the inner front cover).

Categorization by frame (size)

The drive is manufactured in frames (frame sizes) R0, R1, R2, etc. Some instructions and other information which only concern certain frames show the frame size. You

can read the frame size from the type designation label on the drive, refer to [Drive labels](#) on page 33.

Quick installation and commissioning flowchart

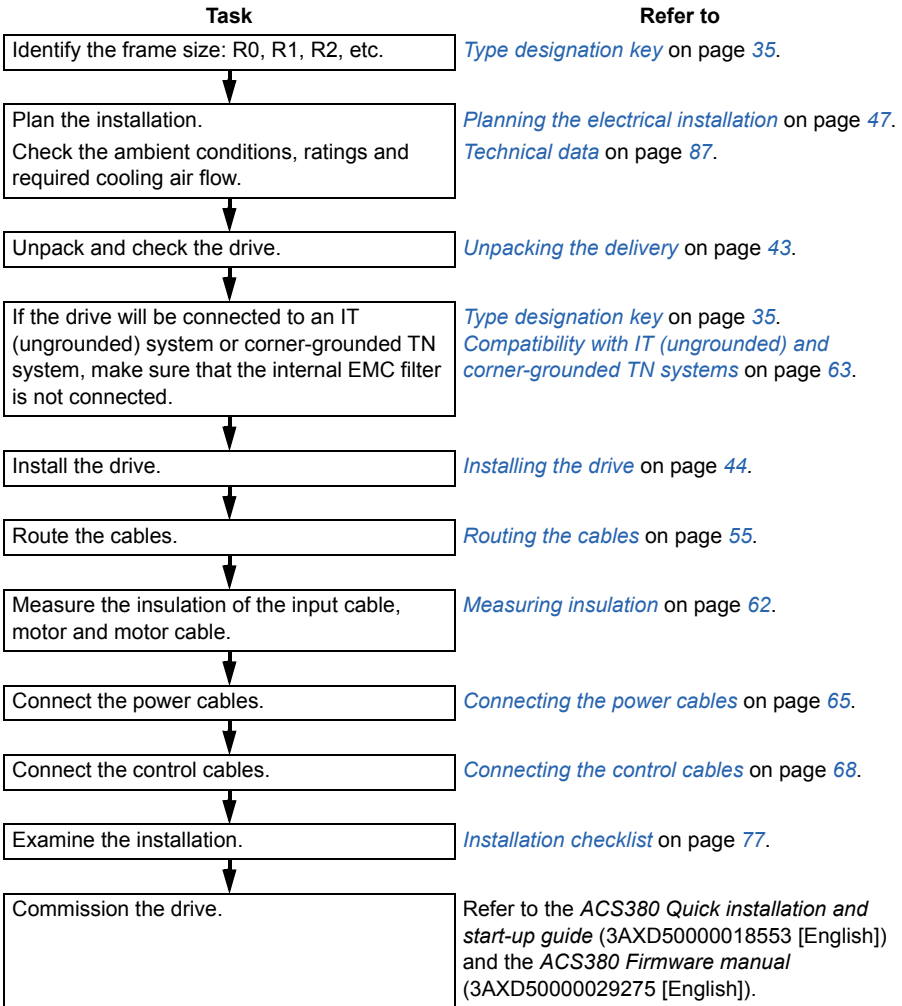

Terms and abbreviations

Term/abbreviation	Explanation
ACS-AP-x	Assistant control panel. An advanced operator keypad for communication with the drive.
Brake chopper	Conducts the surplus energy from the intermediate circuit of the drive to the brake resistor when necessary. The chopper operates when the DC link voltage exceeds a certain maximum limit. The voltage rise is typically caused by deceleration (braking) of a high inertia motor.
Brake resistor	Dissipates the drive surplus braking energy conducted by the brake chopper to heat. Essential part of the brake circuit. Refer to <i>Brake chopper</i> .
Capacitor bank	Refer to <i>DC link capacitors</i> .
Control board	Circuit board in which the control program runs.
BAPO-01	Optional side-mounted auxiliary power extension module
BCAN-11	Optional CANopen interface
BCBL-01	Optional USB to RJ45 cable
BREL-01	Optional side-mounted relay output extension module
BTAC-02	Optional side-mounted pulse encoder interface module
CCA-01	Optional cold configuration adapter
DC link	DC circuit between rectifier and inverter
DC link capacitors	Energy storage which stabilizes the intermediate circuit DC voltage
Drive	Frequency converter for controlling AC motors
EFB	Embedded fieldbus
EMC	Electromagnetic compatibility
FBA	Fieldbus adapter
FCAN-01	Optional CANopen adapter module
FCNA-01	Optional ControlNet adapter module
FDNA-01	Optional DeviceNet adapter module
FECA-01	Optional EtherCAT adapter module
FENA-11/-21	Optional Ethernet adapter module for EtherNet/IP, Modbus TCP and PROFINET IO protocols
FEPL-02	Optional Ethernet POWERLINK adapter module
FPBA-01	Optional PROFIBUS DP adapter module
Frame (size)	Refers to drive physical size, for example, R0 and R1. The type designation label attached to the drive shows the frame of the drive, refer to <i>Type designation key</i> on page 35.
I/O	Input/Output
IGBT	Insulated gate bipolar transistor
Intermediate circuit	Refer to <i>DC link</i> .
Inverter	Converts direct current and voltage to alternating current and voltage.
LRFI	Series of optional EMC filters

Term/abbreviation	Explanation
Macro	Pre-defined default values of parameters in drive control program. Each macro is intended for a specific application.
NETA-21	Optional remote monitoring tool
Network control	With fieldbus protocols based on the Common Industrial Protocol (CIP™), such as DeviceNet and Ethernet/IP, denotes the control of the drive using the Net Ctrl and Net Ref objects of the ODVA AC/DC Drive Profile. For more information, refer to www.odva.org , and the following manuals: <ul style="list-style-type: none"> • <i>FDNA-01 DeviceNet adapter module user's manual</i> (3AFE68573360 [English]) • <i>FENA-01/-11/-21 Ethernet adapter module user's manual</i> (3AUA0000093568 [English])
Parameter	User-adjustable operation instruction to the drive, or signal measured or calculated by the drive
PLC	Programmable logic controller
PROFIBUS, PROFIBUS DP, PROFINET IO	Registered trademarks of PI - PROFIBUS & PROFINET International
R0, R1, ...	<i>Frame (size)</i>
RCD	Residual current device
Rectifier	Converts alternating current and voltage to direct current and voltage.
RFI	Radio-frequency interference
SIL	Safety integrity level. Refer to <i>Safe torque off function</i> on page 139.
STO	Safe torque off. Refer to <i>Safe torque off function</i> on page 139.

3

Hardware description

Contents of this chapter

This chapter describes the operation principle, layout, type designation label and type designation information. It shows a general diagram of the power connections and control interfaces.

General description

The ACS380 is a drive for controlling asynchronous AC induction motors, permanent magnet synchronous motors and ABB synchronous reluctance motors (SynRM motors). It is optimized for cabinet mounting.

Product variants

The drive has three primary product variants:

- Standard variant (ACS380-04xS) with extended I/O & Modbus module
- Configured variant (ACS380-04xC) for which the extension module, such as the preconfigured fieldbus adapter, is chosen when ordering.
- Base variant (ACS380-04xN) without preinstalled extension modules

Refer to [Type designation key](#) on page 35.

Hardware overview

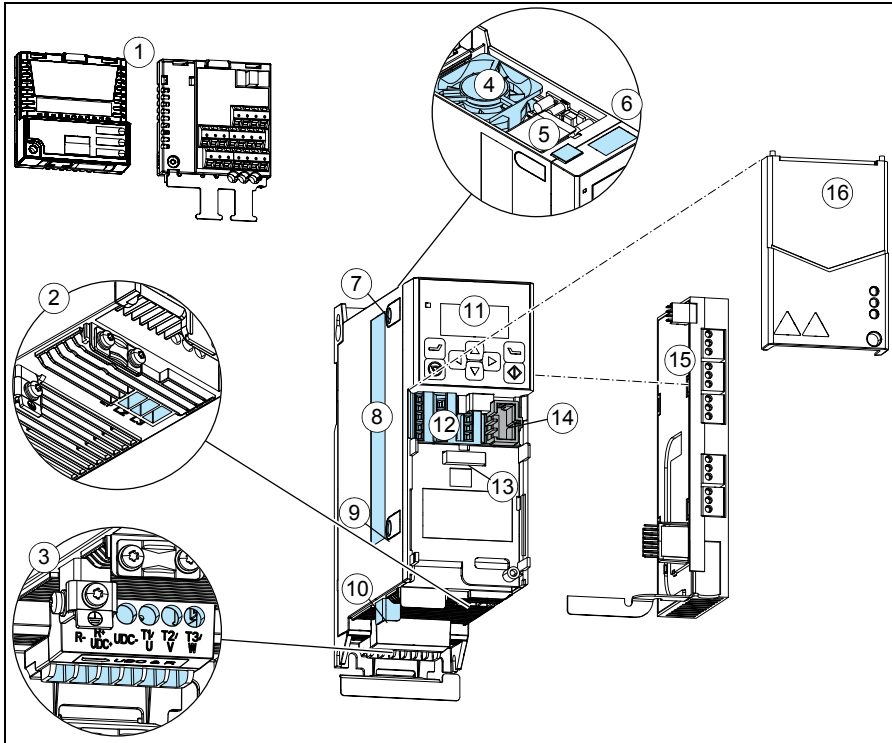

Item	Description	Item	Description
1	Front option modules (I/O and Modbus or Fieldbus module depending on the variant)	9	Varistor grounding screw
2	Input power connection terminal	10	PE connection (motor)
3	Motor and braking resistor connection terminal	11	Control panel, display and status LED
4	Cooling fan	12	Fixed control terminals
5	Panel and PC tool port (RJ45)	13	Option slot 1 for communication modules (I/O or Fieldbus modules)
6	Model information label	14	Cold configuration connection for CCA-01
7	EMC filter grounding screw*	15	Option slot 2 for side-mounted options
8	Type designation label	16	Front cover

* Type codes ACS380-040x-xxxx-1/2 do not have an EMC screw.

Control connections

In addition to the fixed control connections in the base unit, the other control connections depend on the drive variant.

■ Standard variant (I/O and Modbus) (ACS380-04xS)

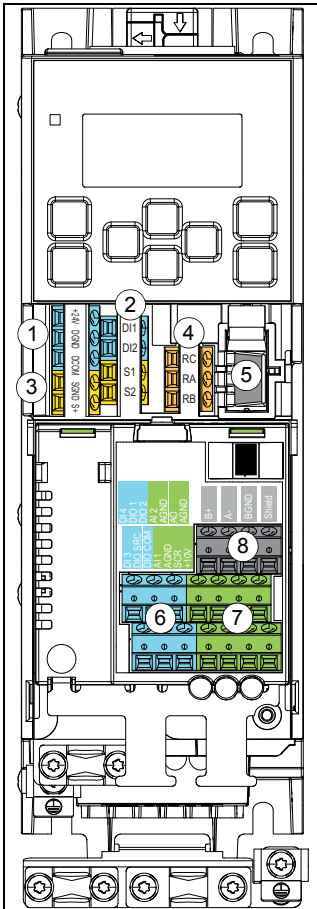

The standard variant has a type code as follows: ACS380-04xS. Refer to [Type designation key](#) on page 35.

Connections:

1. Auxiliary voltage outputs
2. Digital inputs
3. Safe torque-off connections
4. Relay output connection
5. Cold configuration connection for CCA-01
6. Digital inputs and outputs
7. Analog inputs and outputs
8. EIA-485 Modbus RTU

■ **Configured variant (ACS380-04xC)**

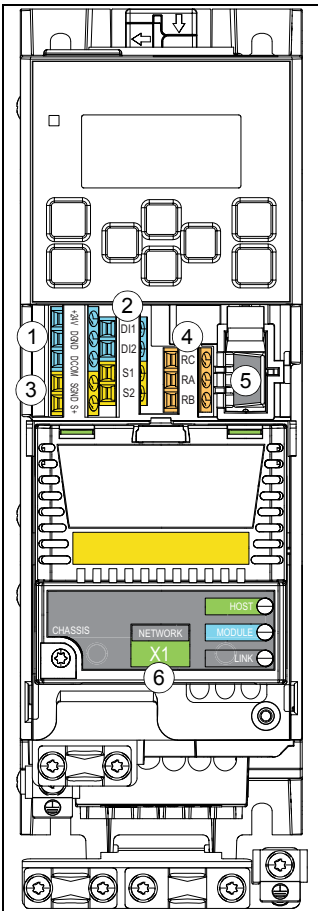

The configured variant has a type code as follows: ACS380-04xC followed by an option code that designates the extension module. Use the configured variant to order a product with a specific fieldbus extension module. Refer to [Type designation key](#) on page 35.

Connections:

1. Auxiliary voltage outputs
2. Digital inputs
3. Safe torque-off connections
4. Relay output connection
5. Cold configuration connection for CCA-01
6. Fieldbus connections depending on the module

■ Base variant (ACS380-04xN)

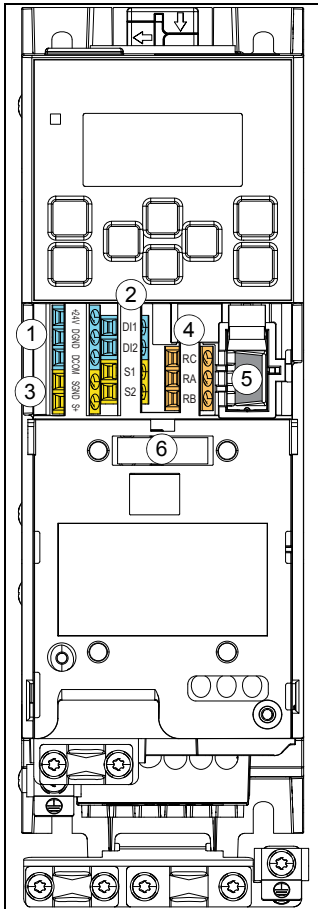

The connections of the base unit:

1. Auxiliary voltage outputs
2. Digital inputs
3. Safe torque-off connections
4. Relay output connection
5. Cold configuration connection for CCA-01
6. Option module slot 1

■ Side-mounted options

For information on side-mounted optional extension modules, refer to:

- [BTAC-02 pulse encoder interface module](#) on page 153
- [BREL-01 relay output extension module](#) on page 171
- [BAPO-01 power extension module](#) on page 177

Control panel options

The drive supports these assistant control panels:

- ACS-AP-I
- ACS-AP-S
- ACS-AP-W
- ACS-BP-S

For information on the assistant control panels, refer to the *ACX-AP-x Assistant control panels user's manual* (3AUA0000085685 [EN]).

PC connection

To connect a PC to the drive, use a USB to RJ45 converter. There are 2 alternatives:

1. Use an ACS-AP-I/S/W assistant control panel as a converter.
2. Use a USB to RJ45 converter. You can order it from ABB (BCBL-01, 3AXD50000032449).

Connect the cable to the Panel and PC tool port (RJ45) on the top of the drive. Refer to [Hardware overview](#) on page 28.

For information on the Drive composer PC tool, refer to *Drive composer PC tool user's manual* (3AUA0000094606 [English]).

Drive labels

The drive has two labels:

- Model information label on the top of the drive
- Type designation label on the left side of the drive

■ Model information label

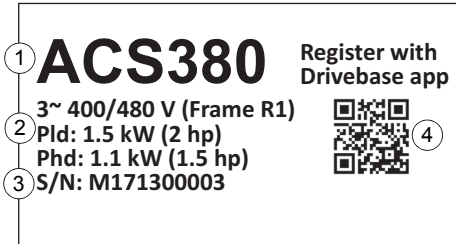

No.	Description
1	Drive type
2	Frame size and ratings
3	Serial number
4	QR code to register the drive

■ Type designation label

This is a sample type designation label.

ABB ABB Oy Hiomotie 13 00380 Helsinki Finland FRAME R1	1 ACS380-040S-04A0-4 4 Input U1 3~ 400/480 VAC f1 50/60 Hz Output U2 3~ 0...U1 Ild 3.8/3.4 A Ihd 3.3/3 A f2 0...599Hz	Input current is scaled by motor output current <table border="1"> <thead> <tr> <th>Output</th> <th>Input</th> <th>Input (with 5% choke)</th> </tr> </thead> <tbody> <tr> <td>4</td> <td>6.4/5.4</td> <td>4/3.4</td> </tr> <tr> <td>3.8/3.4</td> <td>6.1/5.4</td> <td>3.8/3.4</td> </tr> <tr> <td>3.3/3</td> <td>5.3/4.8</td> <td>3.3/3</td> </tr> </tbody> </table>	Output	Input	Input (with 5% choke)	4	6.4/5.4	4/3.4	3.8/3.4	6.1/5.4	3.8/3.4	3.3/3	5.3/4.8	3.3/3	5 EAC 6 UL LISTED IND. CONTEQ. 1PDS CE 7 TÜV NORD TÜV SÜD System Safety Approved
			Output	Input	Input (with 5% choke)										
4	6.4/5.4	4/3.4													
3.8/3.4	6.1/5.4	3.8/3.4													
3.3/3	5.3/4.8	3.3/3													
Air cooling IP20 UL open type	lcc 100 kA 7 S/N: M171300003														

No.	Description
1	Type designation, refer to Type designation key on page 35.
2	Frame (size)
3	Degree of protection
4	Nominal ratings, refer to Ratings on page 88.
5	Valid markings
6	UL/CSA data. Refer to Electric power network specification on page 106.
7	S/N: Serial number of format MYYWWXXXX, where M: Manufacturer YY: Year of manufacture: 15, 16, 17, ... for 2015, 2016, 2017, ... WW: Week of manufacture: 01, 02, 03, ... for week 1, week 2, week 3, ... XXXX: Running item number that starts each week from 0001.

Type designation key

The type designation tells you the specifications and configuration of the drive. The table shows the primary drive variants.

Sample type code: ACS380-042C-02A6-4+K475+L535

Segment		A	B	C		D		E		F
ACS380	-	04	2	C	-	02A6	-	4	+	Option codes

	Code	Description
A	Construction	04 = Module, IP20
B	EMC filter	0 = (400V variant) or C4 (200V Variant) 2 = High filtering level for First environment (EN 61800-3, Class C2)
C	Connectivity	S = Standard variant (I/O and Modbus) (plus code options not available) C = Configured variant
D	Current rating	For example, 02A6 refers to a nominal output current of 2.6 A.
E	Voltage rating	1 = 1-phase 200 to 240 V 2 = 3-phase 200 to 240 V 4 = 3-phase 380 to 480 V
F	Option codes	
	Fieldbus	+K451 FDNA-01 DeviceNet protocol +K454 FPBA-01 Preconfigured Profibus-DP protocol +K457 FCAN-01 Preconfigured CANopen protocol +K469 FECA-01 Preconfigured EtherCAT protocol +K470 FEPL-02 Ethernet Powerlink protocol +K475 FENA-21 Preconfigured Profinet protocol (Ethernet/IP or Modbus/TCP built-in) +K490 FEIP-21 Preconfigured EtherNet/IP protocol +K491 FMBT-21 Preconfigured Modbus/TCP protocol +K492 FPNO-21 Preconfigured PROFINET IO protocol +K495 BCAN-11 Preconfigured CANopen protocol
	I/O	+L511 BREL-01 External relay option (4x relay) (side option) +L534 BAPO-01 External 24 V DC (side option) +L535 BTAC-02 HTL encoder interface + External 24 V DC (side option) +L538 BMIO-01 I/O & Modbus extension module (front option, not available with other front options) +L515 BIO-01 I/O extension module (front option, can be used together with fieldbus)

Code	Description
Documentation	<p>+R700 English +R701 German +R702 Italian +R703 Dutch +R704 Danish +R705 Swedish +R706 Finnish +R707 French +R708 Spanish +R709 Portuguese (in Portugal) +R711 Russian +R712 Chinese +R714 Turkish</p> <p>The option code determines the language variants of the <i>Hardware manual</i> and <i>Firmware manual</i>. The product package includes the <i>User interface guide</i> and <i>Quick installation and start-up guide</i> in English, French, German, Italian and Spanish, and in the local language (if it is available).</p>

Operation principle

The figure shows the simplified main circuit diagram of the drive.

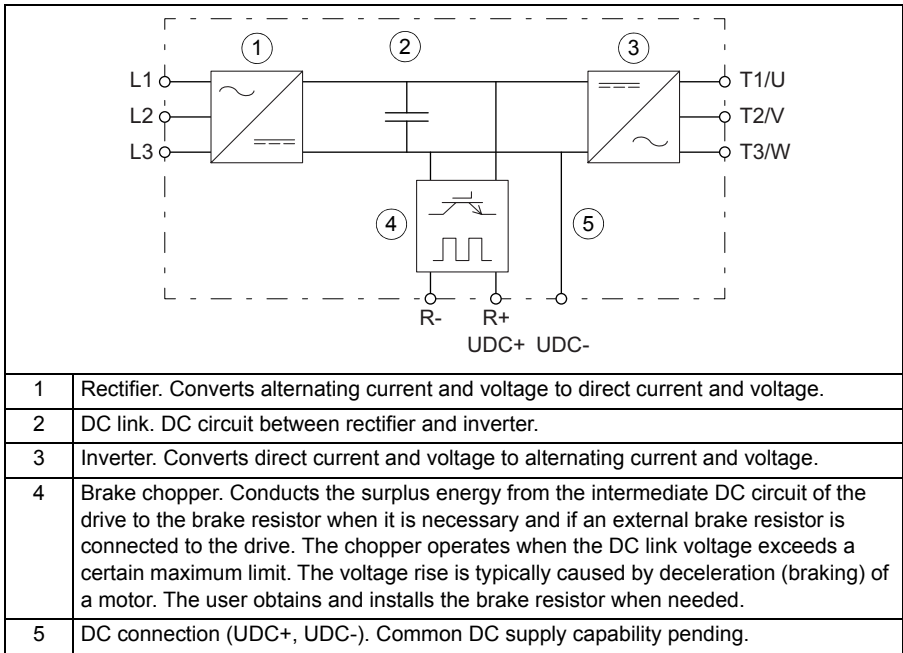

Control panel

The drive has an integrated control panel with a display and control keys.

For quick reference, there is a *ACS380 User interface guide* (3AXD50000022224 [English]) under the main cover of the drive.

Refer to the *ACS380 Firmware manual* (3AXD50000029275 [English]) for information on how to use the interface, start-up the drive and modify settings and parameters.

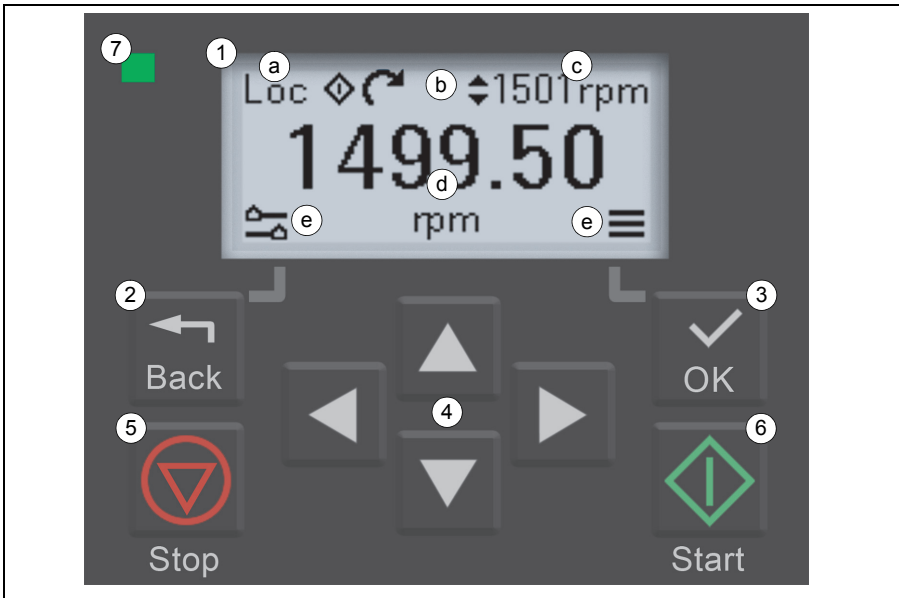

1	<p>Display (<i>Home view</i>):</p> <ul style="list-style-type: none"> a) Control location: local or remote b) Status icons c) Reference target value d) Actual measured value e) Left and right softkey actions
2	<i>Back</i> key (opens the <i>Options</i> view in the <i>Home</i> view)
3	<i>OK</i> key (opens the <i>Menu</i> in the <i>Home</i> view)
4	Arrow keys (menu navigation and setting values)
5	<i>Stop</i> key (when the drive is locally controlled)
6	<i>Start</i> key (when the drive is locally controlled)
7	<p>Status LED:</p> <ul style="list-style-type: none"> Steady green: Normal operation Blicking green: Active warning Steady red: Active fault Blicking red: Active fault, set power to off to reset

The user interface in brief:

- In the *Home* view, push the *Back* key to open the *Options* view.
- In the *Home* view, push the *OK* key to open the *Menu*.
- Navigate the views with the arrow keys.
- Push the *OK* key to open the highlighted setting or item.
- Use the left and right arrow keys to highlight a value.
- Use the up and down keys to set a value.
- Push the *Back* key to cancel a setting or return to the previous view.

■ Home view

The *Home* view shows the reading of one of three measured signals. Select the page with the left and right arrow keys.

The status bar at the top of the *Home* view shows:









- The control location (*Loc* for local control and *Rem* for remote control)
- The status icons
- The reference target value

From the *Home* view, push the *Back* key to open the *Options* view and push the *OK* key to open the *Menu*.

Adjust the current reference value with the up and down arrow keys.

Status icons

The status icons show the operational status of the drive:

Icon	Animation	Description
	None	Local Start/Stop enabled
	None	Stopped
	None	Stopped, start inhibited
	Blinks	Stopped, start commanded but inhibited
	Rotates	Running at reference
	Rotates	Running but not at reference
	Blinks	Running at reference, but reference = 0
	Blinks	Drive fault
	None	Local reference setting enabled

■ **Message view**

When a fault or warning occurs, the display shows the *Message* view. The *Message* view shows either the active fault as an icon and fault code, or a list of the most recent warnings codes.

Refer to the *ACS380 User interface guide* (3AXD50000022224 [English]) or *ACS380 Quick installation and start-up guide* (3AXD50000018553 [English]) for a list of the most typical faults and warnings.

For more detailed fault and warning information, refer to the *ACS380 Firmware manual* (3AXD50000029275 [English]).

To reset a fault, push the *OK* key (with the soft-key label *Reset?*).

■ **Options view**

To open the *Options* view, push the *Back* key in the *Home* view.

In the *Options* view, you can:

- Set the control location
- Set the direction of the motor
- Set the reference
- View the active fault
- View a list of the active warnings

■ **Menu**

To open the *Menu*, push the *OK* key in the *Home* view.

To navigate in the *Menu*, push the up and down arrow keys to move between menu items.

Menu items:

- *Motor data* view: Enter the motor specifications.
- *Motor control* view: Set the motor control settings.
- *Control macros* view: Select the connection parameter macro.
- *Diagnostics* view: Read the active faults and warnings.
- *Energy efficiency* view – Monitor the efficiency of the drive.
- *Parameters* view – Open and edit the full list of parameters.

For detailed information on the user interface, refer to the *ACS380 Firmware manual* (3AXD50000029275 [English]).

4

Mechanical installation

Contents of this chapter

The chapter tells you how to examine the installation site, unpack, check the delivery and install the drive mechanically.

Installation alternatives

You can install the drive:

- With screws on to a wall
- With screws on to an assembly plate
- On to a DIN installation rail (with the integrated lock)



Installation requirements:

- Make sure that there is a minimum of 75 mm of free space at the top and bottom of the drive (at the cooling air inlet and outlet).
- You can install several drives side by side. Note that side-mounted options require 20 mm of space on the right side of the drive.
- Install R0 drives upright. R0 drive do not have a cooling fan.
- You can install R1, R2, R3 and R4 drives tilted by up to 90 degrees, from vertical to fully horizontal orientation.

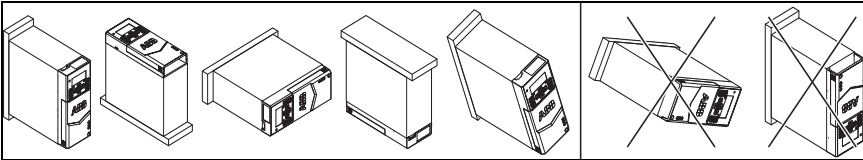

- Make sure that the cooling air exhaust at the top of the drive is not below the cooling air inlet at the bottom of the drive.
- Make sure that the hot cooling air from a drive does not go into the cooling inlet of other equipment.
- The drive has an IP20 ingress protection classification for cabinet installation.

Examining the installation site

Make sure that:

- There is sufficient cooling. Refer to [Losses, cooling data and noise](#) on page 101.
- The operation conditions meet the specifications in [Ambient conditions](#) on page 111.
- The installation surface is as close to vertical as possible, of non-flammable material and strong enough to carry the weight of the drive. Refer to [Dimensions and weights](#) on page 100.
- The material above and below the drive is non-flammable.
- There is sufficient free space above and below the drive for service and maintenance.



Required tools

To install the drive mechanically, you need the following tools:

- A drill and suitable drill bits
- A screwdriver or wrench with a set of suitable bits (PH0–3, PZ0–3, T15–40, S4–7)
(For motor cable terminals, the recommended shaft length is 150 mm)
- A tape measure and spirit level
- Personal protective equipment

Unpacking the delivery

The figure shows the drive package with its contents. Make sure that all of the items are present and that there are no signs of damage.

Package contents:

- Drive
- Options, if ordered with a plus code
- Installation accessories (cable clamps, cable ties, hardware, etc.)
- Mounting template (for R3 and R4 frames only)
- Quick installation and start-up guide
- Hardware and Firmware manuals, if ordered with a plus code



Installing the drive

You can install the drive:

- With screws to a suitable surface (wall or assembly plate)
- To a DIN installation rail with the integrated lock

■ To install the drive with screws

1. Make marks on to the surface for the mounting holes. Refer to *Dimensions and weights* on page 100. Use the mounting template for R3 and R4 frames.
2. Make the holes for the mounting screws.
3. Start to tighten the screws into the mounting holes.
4. Install the drive onto the mounting screws.
5. Tighten the mounting screws.

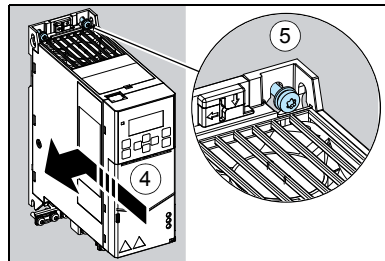
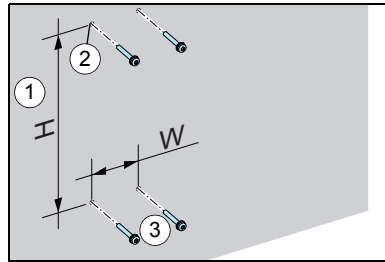

■ To install the drive to a DIN installation rail

1. Move the locking part to the left.
2. Push and hold the locking button down.
3. Put the top tabs of the drive onto the top edge of the DIN installation rail.
4. Put the drive against the bottom edge of the DIN installation rail.
5. Release the locking button.
6. Move the locking part to the right.
7. Make sure that the drive is correctly installed.

To remove the drive, use a flat-head screwdriver to open the locking part.

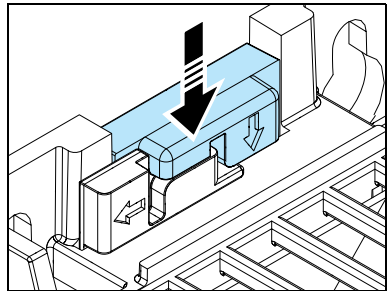
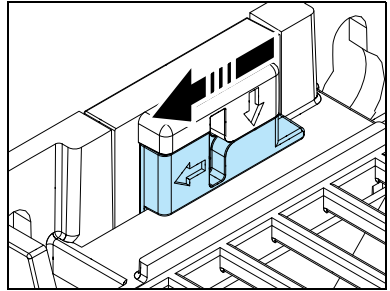



5

Planning the electrical installation

Contents of this chapter

This chapter contains the instructions to plan the electrical installation of the drive, for example, to check the compatibility of the motor and drive, and select the cables, protections as well as cable routing.

Make sure that the installation is designed and done according to the applicable local laws and regulations. ABB does not assume any liability whatsoever for any installation which breaches the local laws and/or other regulations. If the recommendations given by ABB are not followed, the drive may experience problems that the warranty does not cover.

Selecting the supply disconnecting device

Install a hand-operated input disconnecting device between the AC power source and the drive. You must be able to lock the disconnecting device to the open position for installation and maintenance work.

■ European Union

To meet the European Union Directives, according to standard EN 60204-1, *Safety of Machinery*, the disconnecting device must be one of the following types:

- Switch-disconnector of utilization category AC-23B (EN 60947-3).
 - Disconnecter that has an auxiliary contact that in all cases causes switching devices to break the load circuit before the opening of the main contacts of the disconnecter (EN 60947-3).
 - Circuit breaker suitable for isolation in accordance with EN 60947-2.
-

■ Other regions

The disconnecting device must conform to the applicable local safety regulations.

Checking the compatibility of the motor and drive

Use an asynchronous AC induction motor, permanent magnet motor or synchronous reluctance motor (SynRM) with the drive. Several induction motors can be connected to the drive at a time.

Make sure that the motor and the drive are compatible according to the rating table in section *Ratings* on page 88. The table lists the typical motor power for each drive type.

Selecting the power cables

Select the input power and motor cables according to the local regulations:

- The input power and the motor cables must be able to carry the corresponding load currents. Refer to *Ratings* on page 88.
- The cable must be rated for at least 70 °C maximum permissible temperature of conductor in continuous use. For the US, refer to *Additional US requirements* on page 52.
- The conductivity of the PE conductor must be sufficient, refer to page 49.
- A 600 V AC cable is accepted for up to 500 V AC.

To comply with the EMC requirements of the CE mark, use an approved cable type. Refer to *Recommended power cable types* on page 51.

Use a symmetrical shielded cable to decrease:

- The electromagnetic emissions of the drive system.
- The stress on the motor insulation.
- The bearing currents.

The protective conductor must always have an adequate conductivity.

Unless local wiring regulations state otherwise, the cross-sectional area of the protective conductor must agree with the conditions that require automatic disconnection of the supply required in 411.3.2. of IEC 60364-4-41:2005 and be capable of withstanding the prospective fault current during the disconnection time of the protective device.

The cross-sectional area of the protective conductor can either be selected from the table below or calculated according to 543.1 of IEC 60364-5-54.

This table shows the minimum cross-sectional area related to the phase conductor size according to IEC 61800-5-1 when the phase conductor and the protective conductor are made of the same metal. If this is not so, the cross-sectional area of

the protective earthing conductor shall be determined in a manner which produces a conductance equivalent to that which results from the application of this table:

Cross-sectional area of the phase conductors S (mm^2)	Minimum cross-sectional area of the corresponding protective conductor S_p (mm^2)
$S \leq 16$	S
$16 < S \leq 35$	16
$35 < S$	$S/2$

Refer to the IEC/EN 61800-5-1 requirement on grounding on page 17.

■ Typical power cable sizes

These are the typical cross-sectional area of the power cables at the nominal drive current.

Drive type	Frame	mm^2 (Cu) ⁽¹⁾	AWG
1-phase $U_N = 200...240$ V			
ACS380-04xx-02A4-1	R0	$3 \times 1.5 + 1.5$	16
ACS380-04xx-03A7-1	R0	$3 \times 1.5 + 1.5$	16
ACS380-04xx-04A8-1	R1	$3 \times 1.5 + 1.5$	16
ACS380-04xx-06A9-1	R1	$3 \times 1.5 + 1.5$	16
ACS380-04xx-07A8-1	R1	$3 \times 1.5 + 1.5$	16
ACS380-04xx-09A8-1	R2	$3 \times 2.5 + 2.5$	14
ACS380-04xx-12A2-1	R2	$3 \times 2.5 + 2.5$	14
3-phase $U_N = 200...240$ V			
ACS380-04xx-02A4-2	R1	$3 \times 1.5 + 1.5$	16
ACS380-04xx-03A7-2	R1	$3 \times 1.5 + 1.5$	16
ACS380-04xx-04A8-2	R1	$3 \times 1.5 + 1.5$	16
ACS380-04xx-06A9-2	R1	$3 \times 1.5 + 1.5$	16
ACS380-04xx-07A8-2	R1	$3 \times 1.5 + 1.5$	16
ACS380-04xx-09A8-2	R1	$3 \times 2.5 + 2.5$	14
ACS380-04xx-12A2-2	R2	$3 \times 2.5 + 2.5$	14
ACS380-04xx-17A5-2	R3	$3 \times 6 + 6$	14
ACS380-04xx-25A0-2	R3	$3 \times 6 + 6$	10
ACS380-04xx-032A-2	R4	$3 \times 10 + 10$	8
ACS380-04xx-048A-2	R4	$3 \times 25 + 16$	4
ACS380-04xx-055A-2	R4	$3 \times 25 + 16$	4
3-phase $U_N = 380...480$ V			
ACS380-04xx-01A8-4	R0	$3 \times 1.5 + 1.5$	16

Drive type	Frame	mm ² (Cu) ⁽¹⁾	AWG
ACS380-04xx-02A6-4	R1	3×1.5 + 1.5	16
ACS380-04xx-03A3-4	R1	3×1.5 + 1.5	16
ACS380-04xx-04A0-4	R1	3×1.5 + 1.5	16
ACS380-04xx-05A6-4	R1	3×1.5 + 1.5	16
ACS380-04xx-07A2-4	R1	3×1.5 + 1.5	16
ACS380-04xx-09A4-4	R1	3×2.5 + 2.5	14
ACS380-04xx-12A6-4	R2	3×2.5 + 2.5	14
ACS380-04xx-17A0-4	R3	3×6 + 6	10
ACS380-04xx-25A0-4	R3	3×6 + 6	10
ACS380-04xx-032A-4	R4	3×10 + 10	8
ACS380-04xx-038A-4	R4	3×16 + 16	6
ACS380-04xx-045A-4	R4	3×25 + 16	4
ACS380-04xx-050A-4	R4	3×25 + 16	4



1) This is the size of typical power cable (symmetrical, shielded, three-phase copper cable). Note that for the input power connection, you typically must have two separate PE conductors, i.e., the shield alone is not enough. Refer to [Grounding](#) on page 17.

Refer also to [Terminal data for the power cables](#) on page 103.

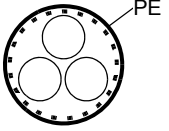
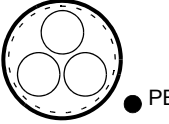
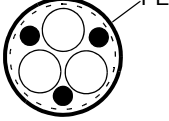
■ Recommended power cable types

	<p>Symmetrical shielded cable with three phase conductors and a concentric PE conductor as shield. The shield must meet the requirements of IEC 61800-5-1, refer to page 48. Check with local / state / country electrical codes for allowance.</p>
	<p>Symmetrical shielded cable with three phase conductors and a concentric PE conductor as the shield. A separate PE conductor is required if the shield does not meet the requirements of IEC 61800-5-1, refer to page 48.</p>
	<p>Symmetrical shielded cable with three phase conductors and symmetrically constructed PE conductor, and a shield. The PE conductor must meet the requirements of IEC 61800-5-1, refer to page 48.</p>

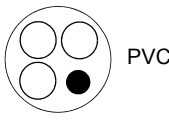
■ Power cable types for limited use

	<p>A four-conductor system (three phase conductors and a protective conductor on a cable tray) is not permitted for motor cabling (it is permitted for input cabling).</p>
	<p>A four-conductor system (three phase conductors and a PE conductor in a PVC conduit) is permitted for input cabling with a phase conductor cross-section less than 10 mm² (8 AWG) or for motors ≤ 30 kW (40 hp). Not permitted in the USA.</p>
	<p>Corrugated or EMT cable with three phase conductors and a protective conductor is permitted for motor cabling with a phase conductor cross section less than 10 mm² (8 AWG) or for motors ≤ 30 kW (40 hp).</p>

■ Not allowed power cable types

	<p>Symmetrical shielded cable with individual shields for each phase conductor is not permitted in any cable size for input or motor cabling.</p>
---	---

■ Motor cable shield

If the motor cable shield is the only protective earth conductor of the motor, make sure that the conductivity of the shield is sufficient. Refer to [Selecting the power cables](#) on page 48 or to IEC 61800-5-1.

To effectively suppress radiated and conducted radio-frequency emissions, the cable shield conductivity must be at least 1/10 of the phase conductor conductivity. To meet the requirements, use a copper or an aluminum shield. The figure shows the minimum requirements for the motor cable shield. It has a concentric layer of copper wires with an open helix of copper tape or copper wire. The better and tighter the shield, the lower the emissions and bearing currents.

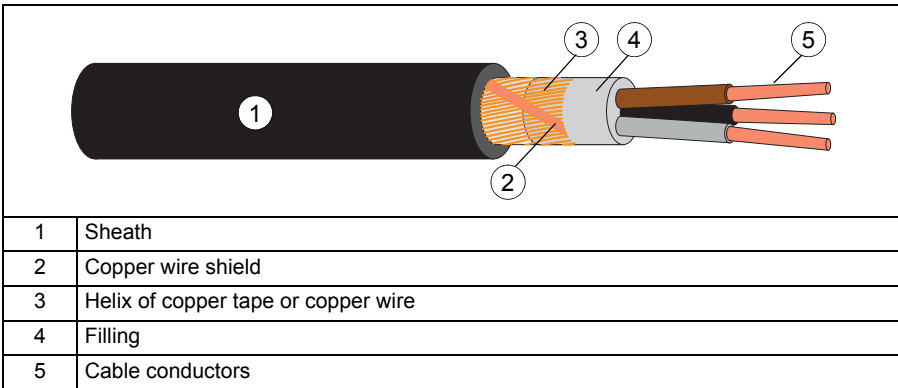

■ Additional US requirements

Use type MC continuous corrugated aluminum armor cable with symmetrical grounds or shielded power cable for the motor cables if metallic conduit is not used. For the North American market, 600 V AC cable is accepted for up to 500 V AC. A 1,000 V AC cable is required above 500 V AC (below 600 V AC). The power cables must be rated for 75 °C (167 °F).

Conduit

Couple separate parts of a conduit together: Bridge the joints with a ground conductor that is bonded to the conduit on each side of the joint. Also bond the conduits to the drive enclosure and motor frame. Use separate conduits for input power, motor, brake resistor and control wiring. When a conduit is used, type MC continuous corrugated aluminum armor cable or shielded cable is not required. A dedicated ground cable is always required.

Do not run motor wiring from more than one drive in the same conduit.

Armored cable or shielded power cable

Six-conductor (three phase and three ground conductors) type MC continuous corrugated aluminum armor cable with symmetrical grounds is available from the following suppliers (trade names in parentheses):

- Anixter Wire & Cable (VFD)
- RSCC Wire and Cable (Gardex)
- Okonite (CLX)

Shielded power cables are available from the following suppliers:

- Belden
 - LAPPKABEL (ÖLFLEX)
 - Pirelli
-

Selecting the control cables

■ Shielding

Only use shielded control cables.

Use a double-shielded twisted pair cable (a) for analog signals. Use one individually shielded pair for each signal. Do not use a common return for different analog signals.

A double-shielded cable (a) is the best alternative for low-voltage digital signals, but a single-shielded (b) twisted pair cable is acceptable.

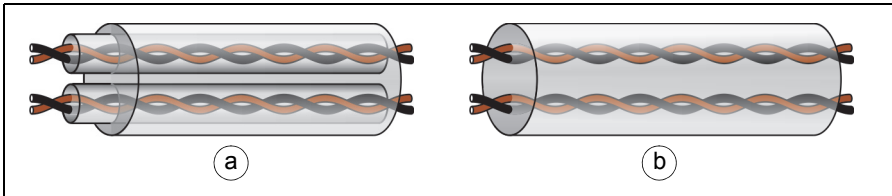

■ Signals in separate cables

Put analog and digital signals in separate, shielded cables.

Do not mix 24 V and 115/230 V AC signals in the same cable.

■ Signals that can be run in the same cable

If their voltage does not exceed 48 V, relay-controlled signals can be in the same cables as digital input signals. The relay-controlled signals should be run as twisted pairs.

■ Relay cable

The cable type with braided metallic screen (for example ÖLFLEX by LAPPKABEL, Germany) has been tested and approved by ABB.

■ Drive composer PC tool cable

Use a USB type A (PC) – type B (control panel) cable. The maximum permitted length of the cable is 3 m (9.8 ft).

Routing the cables

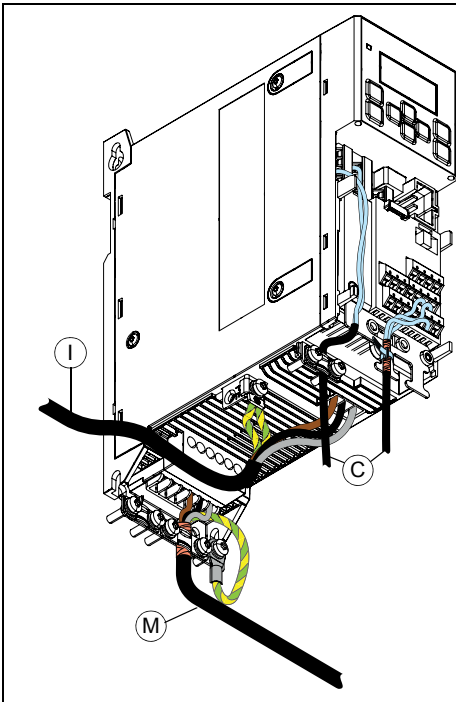

Select the cable routes as follows:

- Put the input power cable (I), motor cable (M) and control cables (C) into separate trays.
 - Put the motor cable (M) away from the other cables.
 - Make sure that there is a minimum of 200 mm between the input power cable (I) and the control cables (C).
 - Make sure that there is a minimum of 500 mm between the motor cable (M) and the control cables (C).
 - Make sure that there is a minimum 300 mm between the input power cable (I) and the motor cable (M).
 - If the control cables cross the input power or motor cables, put the cables at 90 degrees to each other.
 - You can put several motor cables in parallel.
 - Do not install other cables in parallel with the motor cables.
 - Make sure that the cable trays are electrically bonded to each other and to the electrical ground.
- Make sure that the control cables are appropriately supported outside the drive to relieve stress on the cables.
 - Make sure that there are no sources of strong magnetic fields such as high-current single-core conductors or contactor coils near the drive. A strong magnetic field can cause interference or inaccuracy in the operation of the drive. If there is interference, move the source of the magnetic field away from the drive.

■ **Separate control cable ducts**

Put 24 V and 230 V (120 V) control cables in separate ducts unless the 24 V cable is insulated for 230 V (120 V) or insulated with an insulation sleeving for 230 V (120 V).

■ **Continuous motor cable shield or conduit**

To minimize the emission level when there are safety switches, contactors, connection boxes or similar equipment on the motor cable between the drive and the motor: Install the equipment in a metal enclosure with 360 degree grounding for the shields of both the incoming and outgoing cables, or connect the shields otherwise together. If cabling is put into conduits, make sure that they are continuous.

Implementing short-circuit protection

■ **Protecting the drive and input power cable in short-circuits**

Protect the drive and input cable with fuses. For fuse ratings, refer to [Technical data](#) on page 87. The fuses protect the input cable, restrict drive damage and prevent damage to adjoining equipment if there is a short-circuit.

For information on circuit breakers, refer to [Technical data](#) on page 87.

■ **Protecting the motor and motor cable in short-circuits**

If the motor cable has the correct size for the nominal current, the drive protects the motor cable and motor if there is a short-circuit.

Implementing thermal overload protection

■ Protecting the drive, and the input power and motor cables against thermal overload

If the cables have the correct size for the nominal current, the drive protects itself and the input and motor cables against thermal overload.



WARNING! If the drive is connected to several motors, use a separate circuit breaker or fuses to protect each motor cable and motor against overload. The drive overload protection is tuned for the total motor load. It may not trip due to an overload in one motor circuit only.

■ Protecting the motor against thermal overload

According to the regulations, the motor must be protected against thermal overload and the current must be switched off when an overload is detected. The drive has a motor thermal protection function that protects the motor and switches off the current when necessary. Depending on a drive parameter value, the function either monitors a calculated temperature value or an actual temperature indication given by motor temperature sensors. The user can tune the thermal model by feeding in additional motor and load data.

The most common temperature sensors are:

- For motor sizes IEC180...225: a thermal switch, for example, a Klixon.
- For motor sizes IEC200...250 and larger: a PTC or Pt100 sensor.

Protecting the drive against ground faults

The drive has a ground fault protection function that protects the unit against ground faults in the motor and motor cable. It is not a personnel safety or a fire protection feature.

■ Residual current device compatibility

The drive can be used with residual current devices of Type B.

Note: The EMC filter of the drive has capacitors between the main circuit and the frame. These capacitors and long motor cables increase the ground leakage current and can cause the fault current circuit breakers to function.

Implementing the emergency stop function

For safety reasons, install the emergency stop devices at each operator control station and at other operating stations where an emergency stop may be needed. Design the emergency stop according to the applicable standards.

Note: The stop key on the control panel of the drive does not generate an emergency stop or separate the drive from dangerous potential.

Implementing the Safe torque off function

Refer to [Safe torque off function](#) on page 139.

Using a safety switch between the drive and motor

Install a safety switch between the permanent magnet motor and the drive output. The safety switch isolates the motor from the drive during maintenance work.

Using a contactor between the drive and motor

The control of the output contactor depends on how you use the drive.

When you use the vector control mode and motor ramp stop, open the contactor as follows:

1. Give a stop command to the drive.
2. Wait until the drive stops the motor.
3. Open the contactor.

When you use the vector control mode and motor coast stop or the scalar control mode, open the contactor as follows:

1. Give a stop command to the drive.
2. Open the contactor.



WARNING! In the vector control mode, do not open the output contactor when the drive controls the motor. The vector control operates faster than the contactor opens its contacts. If the contactor starts to open when the drive controls the motor, the vector control tries to maintain the load current and increases the output voltage to the maximum. This can cause damage to the contactor.

Protecting the contacts of relay outputs

Inductive loads (relays, contactors and motors) cause voltage transients when switched off. The voltage transients can connect capacitively or inductively to other conductors and cause a malfunction in the system.

Use a noise attenuating circuit (varistors, RC filters [AC] or diodes [DC]) to minimize the EMC emission of inductive loads at switch-off. Install the noise attenuating circuit as close to the inductive load as possible. Do not install a noise attenuating circuit at the relay output.

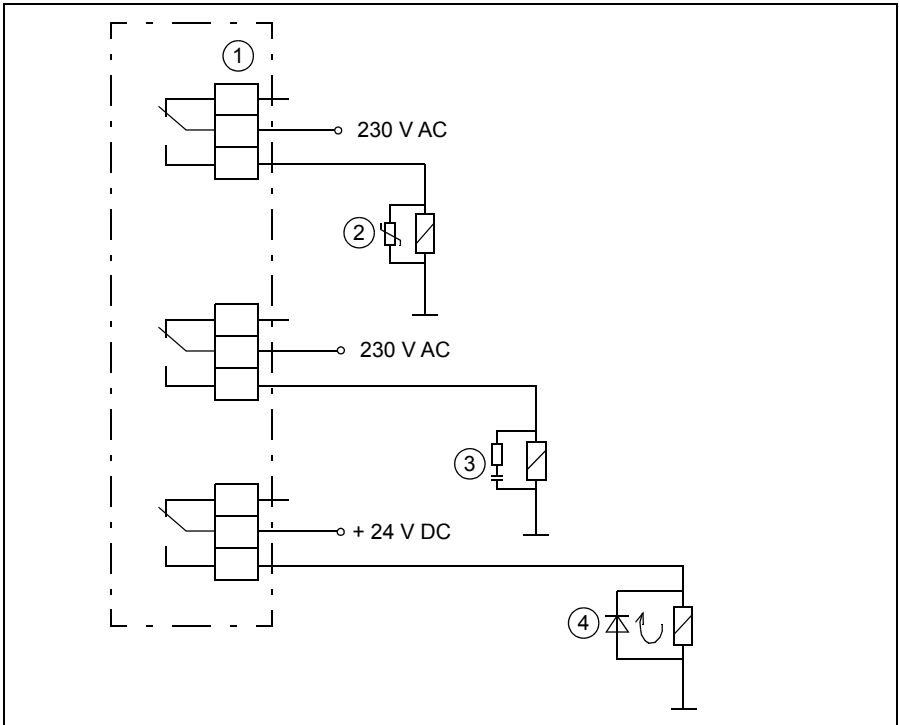

1	Relay output
2	Varistor
3	RC filter
4	Diode

6

Electrical installation

Contents of this chapter

The chapter describes how to check the insulation of the installation and the compatibility with IT (ungrounded) and corner-grounded TN systems. It shows how to connect the power and control cables, install optional modules and connect a PC.

Warnings



WARNING! Obey the instructions in [Safety instructions](#) on page 13. If you ignore them, injury or death, or damage to the equipment can occur.



WARNING! Make sure that the drive is disconnected from the input power during installation. Before you do work on the drive, wait for 5 minutes after you disconnect the input power.



Required tools

To perform the electrical installation, you need the following tools:

- Wire stripper
 - Screwdriver or wrench with a set of suitable bits
 - Multimeter and voltage detector
 - Personal protective equipment
-

Measuring insulation

■ Drive

Do not do voltage tolerance or insulation resistance tests on the drive. The drive was tested for insulation between the main circuit and the chassis at the factory. The drive has voltage-limiting circuits which decrease the testing voltage automatically.

■ Input power cable

Before you connect the input power cable, measure its insulation according to the local regulations.

■ Motor and motor cable

Measure the insulation of the motor and motor cable as follows:

1. Make sure that the motor cable is disconnected from the drive output terminals T1/U, T2/V and T3/W.
2. Measure the insulation resistance between the phase conductors and between each phase conductor and the protective earth conductor. Use a measuring voltage of 1,000 V DC. The insulation resistance of an ABB motor must be more than 100 Mohm (reference value at 25 °C or 77 °F). For the insulation resistance of other motors, refer to the manufacturer's instructions.

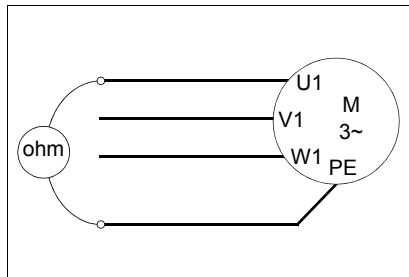

Moisture in the motor casing decreases the insulation resistance. If you think that there is moisture in the motor, dry the motor and measure again.

■ Brake resistor assembly

Measure the insulation of the brake resistor assembly as follows:

1. Make sure that the resistor cable is connected to the resistor, and disconnected from the drive output terminals R+ and R-.
2. At the drive, connect the R+ and R- conductors of the resistor cable together. Measure the insulation resistance between the combined conductors and the PE conductor with a measuring voltage of 1 kV DC. The insulation resistance must be more than 1 Mohm.

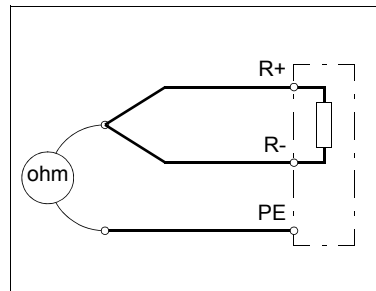

Compatibility with IT (ungrounded) and corner-grounded TN systems

■ EMC filter



WARNING! Do not use the internal EMC filter of the drive in an IT system (an ungrounded power system or a high-resistance-grounded [over 30 ohms] power system). If you use the internal EMC filter, the system is connected to the ground potential through the EMC filter capacitors. This can cause danger or damage to the drive.



WARNING! Do not use the internal EMC filter of the drive in a corner-grounded TN system. If you use the internal EMC filter, this can cause damage to the drive.

When the internal EMC filter is disconnected, the EMC compatibility of the drive decreases. Refer to [Motor cable length](#) on page 107.

■ EMC filter disconnection

This is applicable only to product variants with an internal EMC filter (EMC C2 and C3 variants). Variants with a C4 rating do not have an internal EMC filter.

Refer to [Hardware overview](#) on page 28.

To disconnect the EMC filter, remove the EMC filter grounding screw. In some product variants, the EMC circuit is disconnected from electrical ground at the factory with a non-conducting (plastic) screw. The EMC filter is disconnected on drives with a plastic screw in the EMC filter location. To connect the filter, remove the plastic screw and insert the metal screw and washer from the hardware bag shipped with the drive.

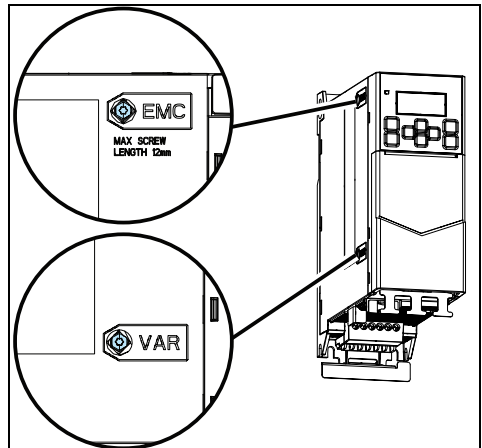

The EMC grounding screw is located on the bottom of the frame in R3 and R4 frames.

■ Ground-to-phase varistor

The metallic varistor screw (VAR) connects the varistor protection circuit to electrical ground.

To disconnect the varistor circuit from ground, remove the varistor grounding screw. Refer to [Hardware overview](#) on page 28.

In some product variants, the varistor protection circuit is disconnected from electrical ground at the factory with a non-conducting (plastic) screw.

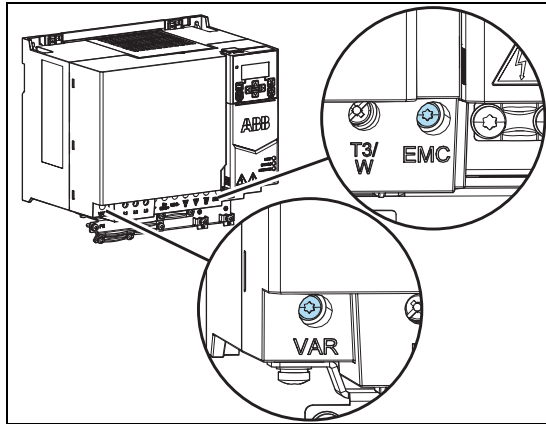

⚠ WARNING! If you connect the drive to an IT system (an ungrounded power system or a high-resistance-grounded [over 30 ohms] power system), disconnect the varistor from ground. Failure to do so can cause damage to the varistor circuit.



Connecting the power cables

■ Connection diagram

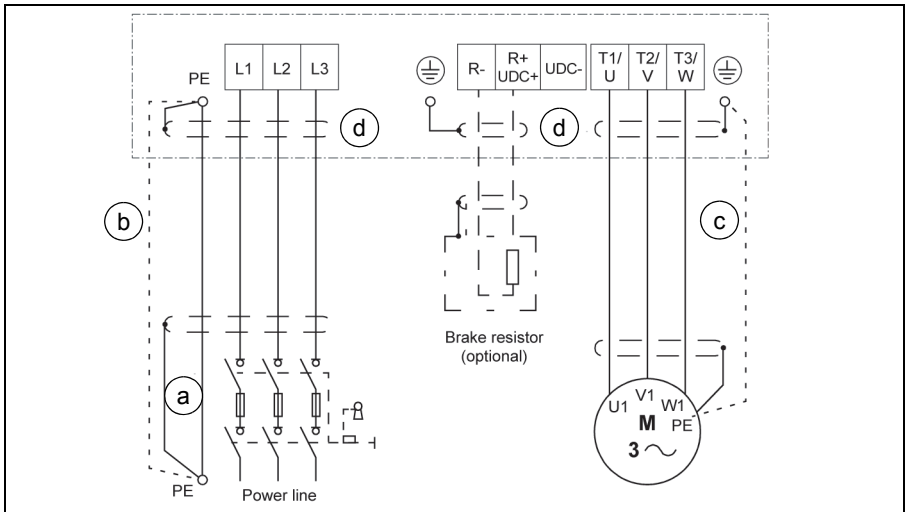

a. Two grounding conductors. Use two conductors, if the cross-section of grounding conductor is less than $10 \text{ mm}^2 \text{ Cu}$ or $16 \text{ mm}^2 \text{ Al}$ (IEC/EN 61800-5-1). For example, use the cable shield in addition to the fourth conductor.

b. Separate grounding cable (line side). Use it if the conductivity of the fourth conductor or shield is not sufficient for the protective grounding.

c. Separate grounding cable (motor side). Use it if the conductivity of the shield is not sufficient for the protective grounding, or there is no symmetrically constructed grounding conductor in the cable.

d. 360-degree grounding of the cable shield. Required for the motor cable and brake resistor cable, recommended for the input power cable.



■ Connection procedure



WARNING! Obey the instructions in chapter *Safety instructions* on page 13. If you ignore them, injury or death, or damage to the equipment can occur.

WARNING! If the drive is connected to an IT (non-grounded) system or to a corner-grounded TN system, disconnect the EMC filter grounding screw. If the drive is connected to an IT (non-grounded) system, disconnect the varistor grounding screw.

Before you start the work, stop the drive and do the steps in *Precautions before electrical work* on page 15.

For information on cable routing, refer to *Routing the cables* on page 55.

For information on correct torques, refer to *Terminal data for the power cables* on page 103.

1. Strip the motor cable.
2. Ground the motor cable shield under the grounding clamp.
3. Twist the motor cable shield into a bundle, put yellow-green insulation tape on it, fit a

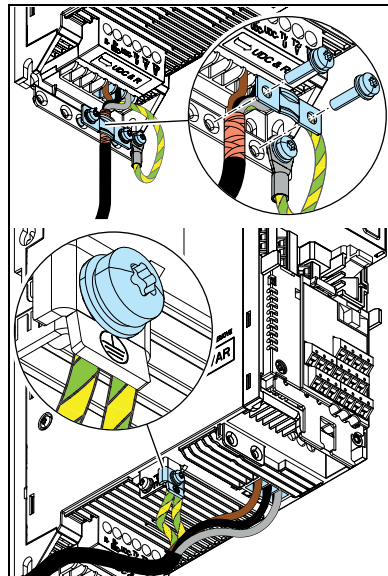

cable lug, and connect it to the grounding terminal.

4. Connect the phase conductors of the motor cable to the T1/U, T2/V and T3/W motor terminals.
5. If it is applicable, connect the brake resistor cable to the R- and UDC+ terminals. Use a shielded cable and ground the shield under the grounding clamp.
6. Strip the input power cable.
7. If the input power cable has a shield, twist it into a bundle, put yellow-green insulation tape on it, fit a cable lug, and connect it to the grounding terminal.
8. Connect the PE conductor of the input power cable to the grounding terminal.
9. If the combined cross-sectional area of the cable shield and PE conductor is not sufficient, use an additional PE conductor.
10. Connect the phase conductors of the input power cable to the L1, L2 and L3 input terminals.
11. Mechanically attach all of the cables on the outside of the drive.



Connecting the control cables

Before you connect the control cables, make sure that all option modules are installed.

Refer to [Default I/O connection diagram \(ABB standard macro\)](#) on page 69 for the default I/O connections of the ABB standard macro. For other macros, refer to the [ACS380 Firmware manual \(3AXD50000029275 \[English\]\)](#).

Connect the cables as shown in [Control cable connection procedure](#) on page 73.



WARNING! Obey the instructions in chapter [Safety instructions](#) on page 13. If you ignore them, injury or death, or damage to the equipment can occur.

Before you start the work, stop the drive and do the steps in section [Precautions before electrical work](#) on page 15.

Remove the front cover.



■ **Default I/O connection diagram (ABB standard macro)**

This connection diagram is valid for drives with the I/O & Modbus extension module:

- Standard variant (ACS380-04xS)
- Configured variant (ACS380-04xC) with the I/O & Modbus extension module (option +L538)

Refer to *Type designation key* on page 35.

Terminals	Descriptions
	Digital I/O connections
	Aux. voltage output +24 V DC, max. 200 mA
	Aux. voltage output common
	Digital input common
	Stop (0)/Start (1)
	Forward (0)/Reverse (1)
	Speed selection
	Speed selection
	Digital input function: Ramp set 1 (0)/Ramp set 2 (1)
	Digital output function: Ready to run (0)/Not ready (1)
	Digital output auxiliary voltage
	Digital input/output common
	Analog I/O
	Output frequency/Speed reference (0...10 V)
Analog input circuit common	
Not configured	
Analog input circuit common	
Output frequency (0...20 mA)	
Analog output circuit common	
Signal cable shield (screen)	
Reference voltage	
Safe torque off (STO)	
Safe torque off function. Connected at factory. Drive starts only when both circuits are closed. Refer to <i>Safe torque off function</i> on page 139.	
Relay output	
Relay output 1	
No fault [Fault (-1)]	
EIA-485 Modbus RTU	
Embedded Modbus RTU (EIA-485)	



Connecting the fieldbus to the drive

Connect the fieldbus to the EIA-485 Modbus RTU terminal on the BMIO-01 module which is attached on the control unit of the drive. The EIA-485 network uses shielded, twisted-pair cable for data signaling with characteristic impedance between 100 and 130 ohm. the distributed capacitance between conductors is less than 100 pF per meter (30 pF per foot). Distributed capacitance between conductors and shield is less than 200 pF per meter (60 pF per foot). foil or braided shields are acceptable. The connection diagram is shown below.

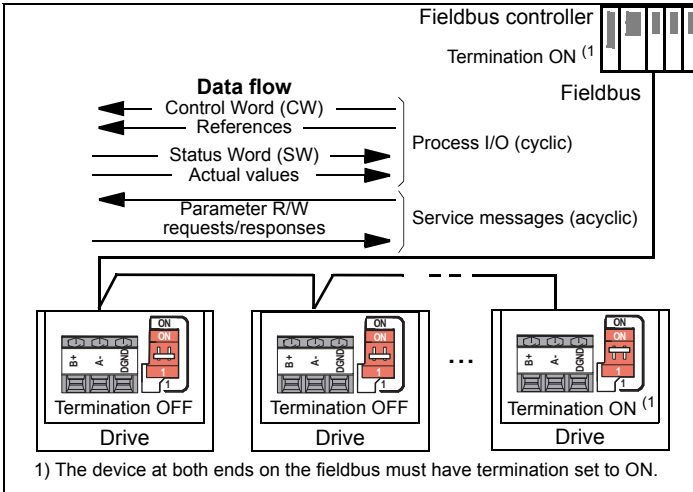

Connection examples of two-wire and three-wire sensors

The figures give examples of connections for a two-wire or three-wire sensor/transmitter that is supplied by the auxiliary voltage output of the drive.

Note: Do not exceed the maximum capability of the auxiliary 24 V (200 mA) output.

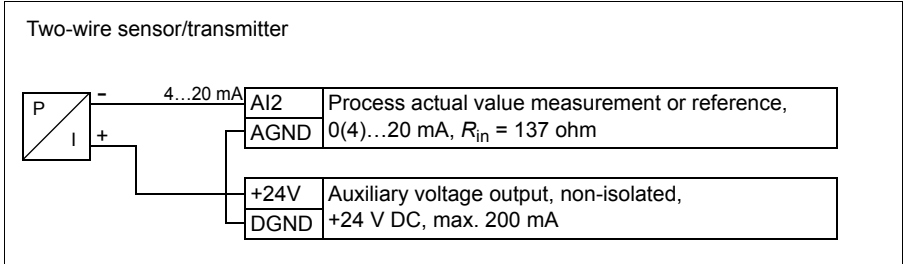

Note: The sensor is supplied through its current output and the drive feeds the supply voltage (+24 V). The output signal must be 4...20 mA, not 0...20 mA.

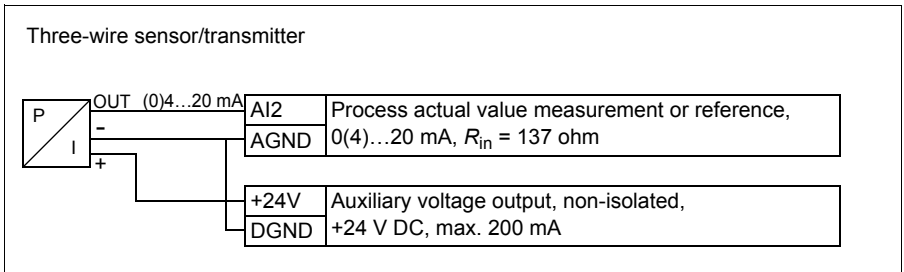

Fieldbus connection diagram

This connection diagram is valid for drives with a fieldbus extension module. The type code is ACS380-04x**C** followed by an option code that designates the extension module. Refer to [Type designation key](#) on page 35.

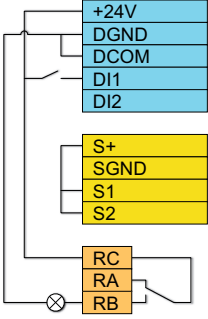
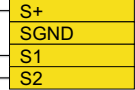
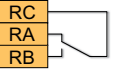
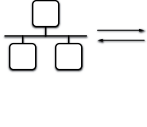
Terminals	Descriptions														
	Aux. voltage output and digital connections														
	+24V Aux. voltage output +24 V DC, max. 200 mA														
	DGND Aux. voltage output common														
	DCOM Digital input common for all														
	DI1 DI2 Fault reset (operates also through the fieldbus interface) Not configured														
	Safe torque off (STO)														
	S+ SGND S1 S2 Safe torque off function. Connected at factory. Drive starts only when both circuits are closed. Refer to Safe torque off function on page 139.														
	Relay output														
	Relay output 1														
	No fault [Fault (-1)]														
 <table border="1" data-bbox="240 710 442 869"> <tbody> <tr> <td>DSUB9</td> <td>CANopen</td> </tr> <tr> <td>DSUB9</td> <td>Profibus DP</td> </tr> <tr> <td>RJ45 X 2</td> <td>EtherCAT</td> </tr> <tr> <td>RJ45 X 2</td> <td>Ethernet IP</td> </tr> <tr> <td>RJ45 X 2</td> <td>Profinet</td> </tr> <tr> <td>RJ45 X 2</td> <td>Modbus TCP</td> </tr> <tr> <td>Terminal Block</td> <td>CANopen</td> </tr> </tbody> </table>	DSUB9	CANopen	DSUB9	Profibus DP	RJ45 X 2	EtherCAT	RJ45 X 2	Ethernet IP	RJ45 X 2	Profinet	RJ45 X 2	Modbus TCP	Terminal Block	CANopen	Extension module options and connections: +K457 FCAN-01 CANopen +K454 FPBA-01 Profibus DP +K469 FECA-01 EtherCAT +K475 FENA-21 Ethernet/IP, Profinet, Modbus TCP +K495 BCAN-11 CANopen interface +K470 FEPL-02, Ethernet Powerlink (RJ45 x2) +K451 FDNA-01, DeviceNet (Terminal Block)
DSUB9	CANopen														
DSUB9	Profibus DP														
RJ45 X 2	EtherCAT														
RJ45 X 2	Ethernet IP														
RJ45 X 2	Profinet														
RJ45 X 2	Modbus TCP														
Terminal Block	CANopen														



■ Control cable connection procedure

Do the connections according to the macro in use. For the default macro connections, refer to the diagram on page 69.

Keep the signal wire pairs twisted as near to the terminals as possible to prevent inductive coupling.

1. Strip a part of the outer shield of the control cable for grounding.
2. Use a cable tie to ground the outer shield to the grounding tab. Use the metallic cable ties for 360-degree grounding.
3. Strip the control cable conductors.
4. Connect the conductors to the correct control terminals. Torque the terminals to 0.5 N·m (4.4 lbf·in).
5. Connect the shields of the twisted pairs and grounding wires to the SCR terminals. Torque the terminals to 0.5 N·m (4.4 lbf·in).
6. Mechanically attach the control cables on the outside of the drive.

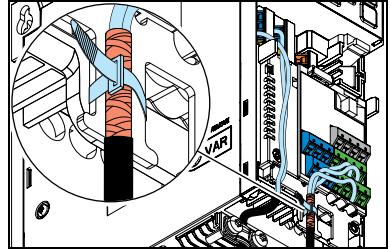

Auxiliary voltage connection

The drive has an auxiliary 24 V DC ($\pm 10\%$) voltage connection. Depending on the application, you can use the connection

- To supply external power to the drive
- To supply power from the drive to external option modules

Connect the external supply or module to the +24V and DGND terminals.

For more information on how to feed auxiliary power to the drive, refer to [BAPO-01 power extension module](#) on page 177.

For voltage input specifications, refer to [Control connection data](#) on page 109.

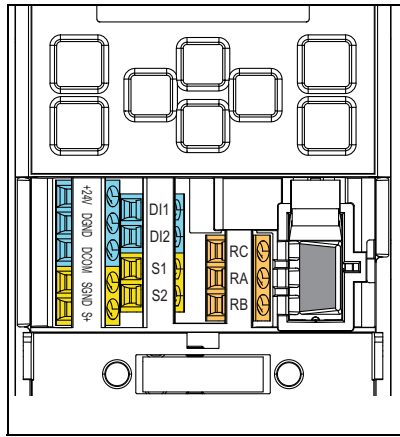

There is a DC to DC flyback converter power supply inside BAPO-01 module. This power supply takes 24 V DC as input and outputs 5 V DC to control board to keep the processor and communication links alive at all times.

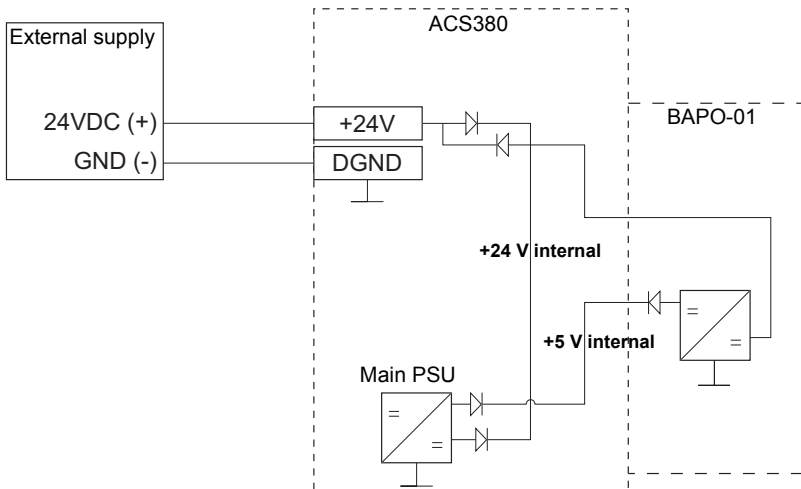

Power supply inside BAPO-01 works alongside the main power supply of the drive and only kicks in when the main power supply shuts down.

Option modules

Typically, option modules are fitted at the factory according to the drive variant or order.



WARNING! Obey the instructions in chapter [Safety instructions](#) on page 13. If you ignore them, injury or death, or damage to the equipment can occur.

The drive has two option module slots:

- Front option: Communication module slot under the front cover.
- Side option: Multifunction extension module slot on the side of the drive.

For more information, refer to the option module manual for installation and wiring instructions. For information on the side-mounted options:

- [BTAC-02 pulse encoder interface module](#) on page 153
- [BREL-01 relay output extension module](#) on page 171
- [BAPO-01 power extension module](#) on page 177

Before you start the work, stop the drive and do the steps in section [Precautions before electrical work](#) on page 15.

■ To install a front option

1. Remove the front cover.
2. If you have the BIO-01 option module, you can add one additional fieldbus module on top of it. Use the high front cover.
3. Carefully align the option module with Slot 1 in the front of the drive.
4. Fully push the option module into position.
5. Push the plastic locking tab until it locks.
6. Tighten the locking screw.
7. Connect the applicable control cables according to [Connecting the control cables](#) on page 68.

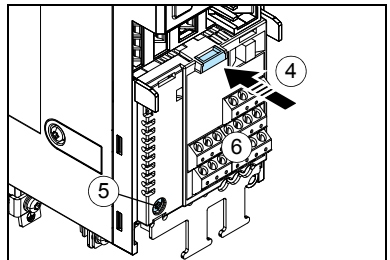
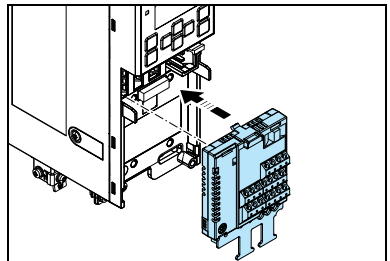

■ To remove a front option

1. Disconnect the control cables from the option module.
2. Loosen the locking screw.
3. Carefully pull the option module to disconnect it. Note that the option module can be tightly in position.

■ To install a side option

1. Remove the two screws from the front-most grounding clamp at the bottom of the drive.
2. Carefully align the side option with the connectors on the right side of the drive.
3. Fully push the option module into position.

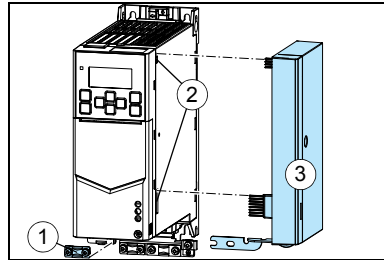

4. Tighten the locking screw of the option module.
5. Attach the grounding bar to the bottom of the side option and to the front ground tab on the drive.
6. Connect the applicable control cables according to [Connecting the control cables](#) on page 68.

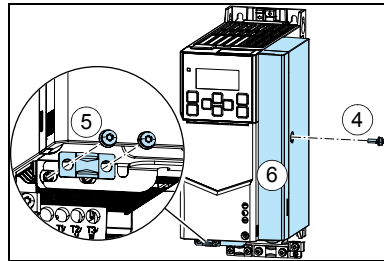

■ To remove a side option

1. Disconnect the control cables from the side option.
2. Open the grounding bar screws.
3. Loosen the locking screw.
4. Carefully remove the side option from the drive. Note that the option module can be tightly in position.



7

Installation checklist

Contents of this chapter

This chapter contains an installation checklist which you must complete before you start up the drive.

Warnings



WARNING! Obey the instructions in chapter [Safety instructions](#) on page 13. If you ignore them, injury or death, or damage to the equipment can occur.

Checklist

Do the steps in [Precautions before electrical work](#) on page 15 before you start the work. Read the checklist together with another person.

<input checked="" type="checkbox"/>	Make sure that ...
<input type="checkbox"/>	The ambient operating conditions meet the specification in Ambient conditions on page 111.
<input type="checkbox"/>	If the drive is connected to an IT (ungrounded) or corner-grounded TN supply network: Internal EMC filter is disconnected. If the drive is connected to an IT (non-grounded) system, disconnect the varistor grounding screw. Refer to Compatibility with IT (ungrounded) and corner-grounded TN systems on page 63.
<input type="checkbox"/>	If the drive is stored over one year: The electrolytic DC capacitors in the DC link of the drive are reformed. Refer to Servicing the capacitors on page 85.

<input checked="" type="checkbox"/>	Make sure that ...
<input type="checkbox"/>	There is an adequately sized protective earth (ground) conductor between the drive and the switchboard.
<input type="checkbox"/>	There is an adequately sized protective earth (ground) conductor between the motor and the drive.
<input type="checkbox"/>	All protective earth (ground) conductors are connected to the correct terminals and the terminals are tightened (pull the conductors to check).
<input type="checkbox"/>	The supply voltage matches the nominal input voltage of the drive. Read the type designation label.
<input type="checkbox"/>	The input power cable is connected to the correct terminals, the phase order is right, and the terminals are tightened. (Pull the conductors to check.)
<input type="checkbox"/>	Appropriate supply fuses and disconnector are installed.
<input type="checkbox"/>	The motor cable is connected to the correct terminals, the phase order is right, and the terminals are tightened. (Pull the conductors to check.)
<input type="checkbox"/>	The brake resistor cable (if present) is connected to the correct terminals, and the terminals are tightened. (Pull the conductors to check.)
<input type="checkbox"/>	The motor cable (and brake resistor cable, if present) is routed away from other cables.
<input type="checkbox"/>	The control cables (if any) are connected.
<input type="checkbox"/>	If a drive bypass connection is used: The direct-on-line contactor of the motor and the drive output contactor are mechanically or electrically interlocked (cannot be closed simultaneously).
<input type="checkbox"/>	There are no tools, foreign objects or dust inside the drive. There is no dust near the air inlet of the drive.
<input type="checkbox"/>	The drive cover is in place.
<input type="checkbox"/>	The motor and the driven equipment are ready for start-up.



Maintenance

Contents of this chapter

The chapter contains the preventive maintenance instructions and LED indicator descriptions.

Maintenance intervals

The table shows the maintenance tasks which can be done by the user. The complete maintenance schedule is available at www.abb.com/drivesservices. For more information, speak to your local ABB Service representative (www.abb.com/searchchannels).

Maintenance task/object	Years from start-up													
	0	1	2	3	4	5	6	7	8	9	10	11	12	...
Cooling fans														
Main cooling fan. Refer to page 82.				(R)			R (R)			(R)			R (R)	
Connections and environment														
Quality of supply voltage		O	O	O	O	O	O	O	O	O	O	O	O	O
Improvements														
Based on product notes				I			I			I			I	
Spare parts														
Spare part stock		I	I	I	I	I	I	I	I	I	I	I	I	I
Reform DC circuit capacitors (spare modules and spare capacitors). Refer to page 85.		O	O	O	O	O	O	O	O	O	O	O	O	O
Other useful tasks														
Tightness of the cable and busbar terminals. Tighten if needed.		I	I	I	I	I	I	I	I	I	I	I	I	I
Ambient conditions (dustiness, moisture and temperature)		I	I	I	I	I	I	I	I	I	I	I	I	I
Clean the heatsink. Refer to page 81.		O	O	O	O	O	O	O	O	O	O	O	O	O

Symbols

- I Inspection**, maintenance action if it is necessary
- (I) Inspection** in harsh conditions*, maintenance action if it is necessary
- R Replacement**
- (R) Replacement** in harsh conditions*
- O Other work** (commissioning, tests, measurements, etc.)

* Surrounding air temperature constantly over 40 °C, very dusty or humid conditions, cyclic heavy load, or continuous nominal (full) load.

To maintain the performance and reliability of the drive, examine the drive annually. Contact ABB Service at least once in three years to replace old components.

The recommended maintenance and component replacement intervals are based on operation in specified ambient conditions.

Cleaning the heat sink

The fins of the drive heat sink become dusty from the cooling air. If the heat sink is not clean, this can cause the drive to give overtemperature warnings and faults.



WARNING! Obey the instructions in [Safety instructions](#) on page 13. Ignoring the instructions can cause physical injury or death, or damage to the equipment.



WARNING! Use a vacuum cleaner with an antistatic hose and nozzle. A normal vacuum cleaner can cause static discharges which can cause damage to circuit boards.

To clean the heat sink:

1. Stop the drive and disconnect it from the input power.
 2. Wait for 5 minutes and measure to make sure that there is no voltage. Refer to [Precautions before electrical work](#) on page 15.
 3. Remove the cooling fan. Refer to [Replacing the cooling fans](#) on page 82.
 4. Blow clean, dry and oil free compressed air from the bottom of the heat sink to the top and use a vacuum cleaner at the air outlet to trap the dust.
If there is a risk that dust can go into other equipment, clean the heat sink in another room.
 5. Install the cooling fan.
-

Replacing the cooling fans

This instruction is applicable only to frame sizes R1, R2, R3 and R4. Frame R0 does not have a cooling fan.

Refer to *Maintenance intervals* on page 80 for the fan replacement interval in normal operating conditions. Parameter 05.04 Fan on-time counter shows the running time of the cooling fan. After you replace the fan, reset the fan counter. Refer to the *ACS380 Firmware manual* (3AXD50000029275 [English]).

You can get replacement fans from ABB. Use only ABB specified spare parts.

■ To replace the cooling fan for frames R1–R3



WARNING! Obey the instructions in *Safety instructions* on page 13. Ignoring the instructions can cause physical injury or death, or damage to the equipment.

1. Stop the drive and disconnect it from the power line.
2. Wait for 5 minutes and measure to make sure that there is no voltage. Refer to *Precautions before electrical work* on page 15.
3. Use a suitable flat screwdriver to open the fan cover.
4. Carefully lift the fan cover out of the drive. Note that the fan cover holds the cooling fan.

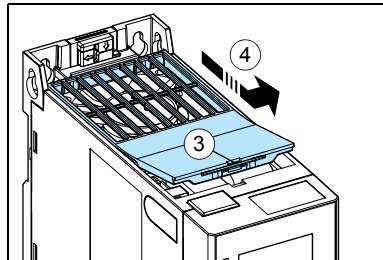

5. Remove the fan power cable from the cable slot in the drive.
6. Disconnect the fan power cable.

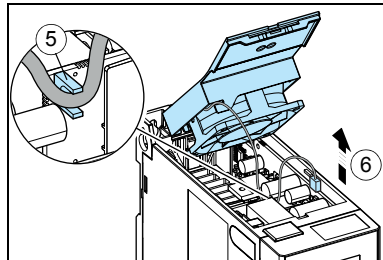

7. Free the fan clips and remove the fan from the fan cover.
8. Install the new fan into the fan cover. Make sure that the air flow is in the correct direction. The air flows in from the bottom of the drive and out from the top of the drive.

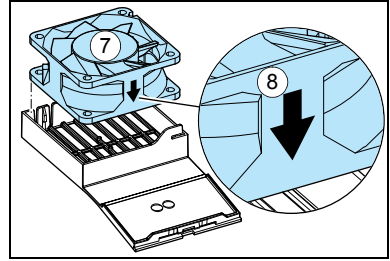

9. Connect the fan power cable.
10. Put the fan power cable into the cable slot in the drive.

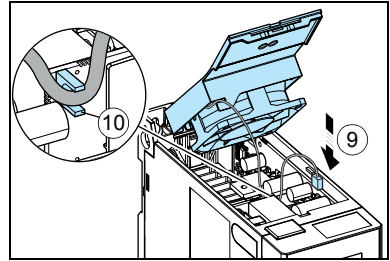

11. Carefully put the fan cover into position in the drive. Make sure that the fan power cable is routed correctly.
12. Push the cover to lock into position.

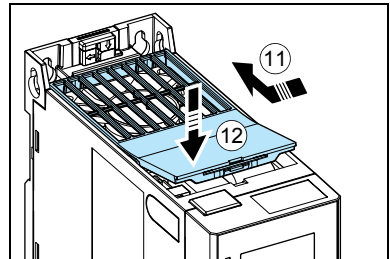

■ To replace the cooling fan for frame R4



WARNING! Obey the instructions in [Safety instructions](#) on page 13. Ignoring the instructions can cause physical injury or death, or damage to the equipment.

1. Wait for 5 minutes and measure to make sure that there is no voltage. Refer to [Precautions before electrical work](#) on page 15.
2. Stop the drive and disconnect it from the power line.
3. Use a suitable flat screwdriver to open the fan cover.
4. Lift out the fan cover and set it aside.
5. Lift and pull the fan from its base.
6. Unplug the fan power cable from the extension cable connector.
7. Replace the old fan carefully. Pay attention to the correct installation direction of the fan by following the arrow markings on the fan, they must point up and to the left. When installed correctly, the fan creates suction within the drive and blows it outwards.
8. Attach the fan power cable to the connector.
9. Place the fan cover back on the frame.
10. Push the cover to lock into position.

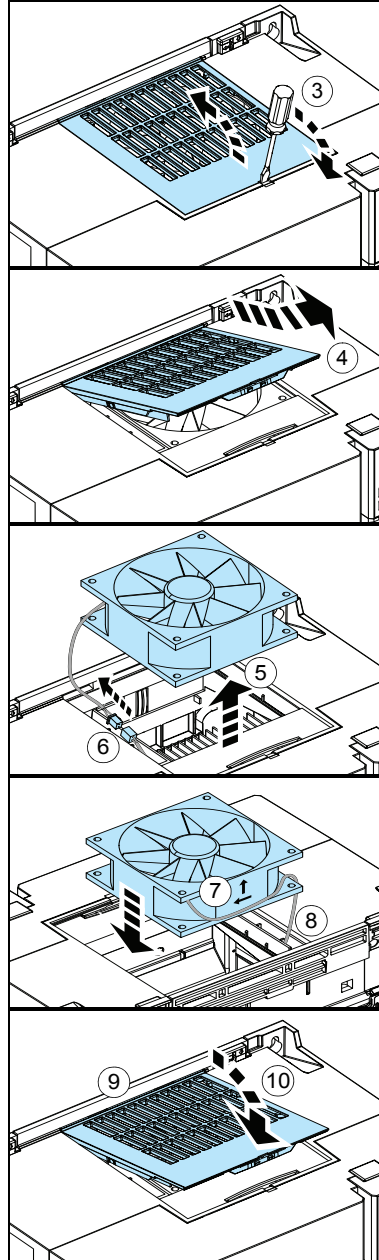

Servicing the capacitors

The intermediate DC circuit of the drive has electrolytic capacitors. Their lifespan depends on the operating time and loading of the drive, and the surrounding air temperature.

Capacitor failure can cause damage to the drive and an input cable fuse failure, or a fault in the drive. Contact ABB if you think that a capacitor failed. You can get spare parts from ABB. Use only ABB specified spare parts.

■ Capacitor reforming

You must reform the capacitors if the drive is stored for a year or more. Refer to [Drive labels](#) on page 33 to read the manufacturing date from the serial number.

To reform the capacitors, refer to *Converter module capacitor reforming instructions* (3BFE64059629), available on the Internet (go to www.abb.com and enter the code in the Search field).

A large, light blue square with rounded corners, centered on the page. Inside the square is a large, bold, black number '9'.

Technical data

Contents of this chapter

The chapter contains the technical specifications of the drive, such as ratings, sizes and technical requirements as well as provisions for fulfilling the requirements for CE, UL and other approval marks.

Ratings

IEC ratings

Type ACS380- 04xx	Input		Output ratings							Frame size
	rating	with choke	Max. current	Nominal use		Light-duty use		Heavy-duty use		
	I_{IN}	I_{IN}	I_{max}	I_N	P_N	I_{Ld}	P_{Ld}	I_{Hd}	P_{Hd}	
	A	A	A	A	kW	A	kW	A	kW	
1-phase $U_N = 200...240$ V										
02A4-1	5.0	4.2	3.2	2.4	0.37	2.3	0.37	1.8	0.25	R0
03A7-1	7.8	6.4	4.3	3.7	0.55	3.5	0.55	2.4	0.37	R0
04A8-1	10.1	8.3	6.7	4.8	0.75	4.6	0.75	3.7	0.55	R1
06A9-1	14.5	11.9	8.6	6.9	1.10	6.6	1.10	4.8	0.75	R1
07A8-1	16.4	13.5	12.4	7.8	1.5	7.4	1.5	6.9	1.1	R1
09A8-1	20.6	17.0	14.0	9.8	2.2	9.3	2.2	7.8	1.5	R2
12A2-1	25.6	21.1	17.6	12.2	3.0	11.6	3.0	9.8	2.2	R2
3-phase $U_N = 200...240$ V										
02A4-2	3.8	2.4	2.2	2.4	0.37	2.3	0.37	1.2	0.25	R1
03A7-2	5.9	3.7	3.2	3.7	0.55	3.5	0.55	1.8	0.37	R1
04A8-2	7.7	4.8	6.7	4.8	0.75	4.6	0.75	3.7	0.55	R1
06A9-2	11.0	6.9	8.6	6.9	1.1	6.6	1.1	4.8	0.75	R1
07A8-2	12.5	7.8	12.4	7.8	1.5	7.4	1.5	6.9	1.1	R1
09A8-2	15.7	9.8	14.0	9.8	2.2	9.3	2.2	7.8	1.5	R1
12A2-2	19.5	12.2	17.6	12.2	3.0	11.6	3.0	9.8	2.2	R2
17A5-2	28.0	17.5	22.0	17.5	4.0	16.7	4.0	12.2	3.0	R3
25A0-2	40.0	25.0	31.5	25.0	5.5	24.2	5.5	17.5	4.0	R3
032A-2	51.2	32.0	45.0	32.0	7.5	30.8	7.5	25.0	5.5	R4
048A-2	76.8	48.0	57.6	48.0	11.0	46.2	11.0	32.0	7.5	R4
055A-2	88.0	55.0	86.4	55.0	15.0	59.4	15.0	48.0	11	R4
3-phase $U_N = 380...480$ V										
01A8-4	2.9	1.8	2.2	1.8	0.55	1.7	0.55	1.2	0.37	R0
02A6-4	4.2	2.6	3.2	2.6	0.75	2.5	0.75	1.8	0.55	R1
03A3-4	5.3	3.3	4.7	3.3	1.1	3.1	1.1	2.6	0.75	R1
04A0-4	6.4	4.0	5.9	4.0	1.5	3.8	1.5	3.3	1.1	R1
05A6-4	9.0	5.6	7.2	5.6	2.2	5.3	2.2	4.0	1.5	R1
07A2-4	11.5	7.2	10.1	7.2	3.0	6.8	3.0	5.6	2.2	R1
09A4-4	15.0	9.4	13.0	9.4	4.0	8.9	4.0	7.2	3.0	R1
12A6-4	20.2	12.6	16.9	12.6	5.5	12.0	5.5	9.4	4.0	R2
17A0-4	27.2	17.0	22.7	17.0	7.5	16.2	7.5	12.6	5.5	R3
25A0-4	40.0	25.0	30.6	25.0	11.0	23.8	11.0	17.0	7.5	R3
032A-4	45.0	32.0	45.0	32.0	15.0	30.5	15.0	25.0	11.0	R4
038A-4	50.0	38.0	57.6	38.0	18.5	36.0	18.5	32.0	15.0	R4
045A-4	56.0	45.0	68.4	45.0	22.0	42.8	22.0	38.0	18.5	R4
050A-4	60.0	50.0	81.0	50.0	22.0	48.0	22.0	45.0	22.0	R4

3AXD10000299801.xls

NEMA ratings

Type ACS380-04xx-	Input rating	Input with choke	Output ratings				Frame size
			Light-duty use		Heavy-duty use		
	I_{1N}	I_{1N}	I_{Ld}	P_{Ld}	I_{Hd}	P_{Hd}	
	A	A	A	hp	A	hp	
3-phase $U_N = 460$ V (440...480 V)							
01A8-4	2.6	1.6	1.6	0.75	1.1	0.50	R0
02A6-4	3.4	2.1	2.1	1.0	1.6	0.75	R1
03A3-4	4.8	3.0	3.0	1.5	2.1	1.0	R1
04A0-4	5.4	3.4	3.5	2.0	3.0	1.5	R1
05A6-4	7.7	4.8	4.8	2.0	3.4	2.0	R1
07A2-4	9.6	6.0	6.0	3.0	4.0	2.0	R1
09A4-4	12.2	7.6	7.6	5.0	4.8	3.0	R1
12A6-4	17.6	11.0	11.0	7.5	7.6	5.0	R2
17A0-4	22.4	14.0	14.0	10.0	11.0	7.5	R3
25A0-4	33.6	21.0	21.0	15.0	14.0	10.0	R3
032A-4	37.9	27.0	27.0	20.0	12.0	15.0	R4
038A-4	44.7	34.0	34.0	25.0	27.0	20.0	R4
045A-4	49.8	40.0	40.0	30.0	34.0	25.0	R4
050A-4	50.4	42.0	42.0	30.0	40.0	30.0	R4

3AXD10000299801.xls

Definitions

U_N	Nominal supply voltage
I_{1N}	Nominal input current. Continuous rms input current (for dimensioning cables and fuses).
I_{max}	Maximum output current. Available for two seconds at start.
I_N	Nominal output current. Maximum continuous rms output current allowed (no overload).
P_N	Nominal power of the drive. Typical motor power (no overloading). The kilowatt ratings apply to most IEC 4-pole motors. The horsepower ratings apply to most NEMA 4-pole motors.
I_{Ld}	Maximum current with 110% overload, allowed for one minute every ten minutes
P_{Ld}	Typical motor power in light-duty use (110% overload)
I_{Hd}	Maximum current with 150% overload, allowed for one minute every ten minutes
P_{Hd}	Typical motor power in heavy-duty use (150% overload)

Sizing

Drive sizing is based on the rated motor current and power. To achieve the rated motor power, the rated current of the drive must be more than or equal to the rated motor current. Also, the rated power of the drive must be more than or equal to the rated motor power. The power ratings are the same regardless of the supply voltage in one voltage range.

The ratings are valid at a surrounding air temperature of 50 °C (104 °F) for I_N . When the temperature increases, derating is required.

The DriveSize dimensioning tool available from ABB is recommended for selecting the drive, motor and gear combination.

Derating

The load capacity (I_N , I_{LD} , I_{HD} ; note that I_{max} is not derated) decreases in certain situations. In such situations, where full motor power is required, oversize the drive so that the derated value provides sufficient capacity.

If several situations are present at a time, the effects of derating are cumulative.

Example:

If your application requires continuous 6.0 A of motor current (I_N) at 8 kHz switching frequency, the supply voltage is 400 V and the drive is situated at 1500 m, calculate the appropriate drive size requirement as follows:

Switching frequency derating (page 91):

From the table, the minimum size required is $I_N = 9.4$ A.

Altitude derating (page 92):

The derating factor for 1500 m is $1 - 1/10\,000 \text{ m} \cdot (1500 - 1000) \text{ m} = 0.95$.

The minimum size required becomes then $I_N = 9.4 \text{ A} / 0.95 = 9.9$ A.

Referring to I_N in the ratings tables (starting from page 88), drive type ACS380-04xx-12A6-4 exceeds the I_N requirement of 9.9 A.

■ Surrounding air temperature derating, IP20

Frame size	Temperature	Derating
R0...R4	up to +50 °C up to +122 °F	No derating.
R1...R3	+50...+60 °C +122...+140 °F	Output current is decreased by 1% for every additional 1 °C (1.8 °F).
R4	+50...+60 °C +122...+140 °F	Output current is decreased by 1% for every additional 1 °C on: <ul style="list-style-type: none"> • ACS380-04xx-032A4-4 • ACS380-04xx-045A-4 Output current is decreased by 2% for every additional 1 °C on: <ul style="list-style-type: none"> • ACS380-04xx-038A-4 • ACS380-04xx-050A-4

■ Switching frequency derating

Type ACS380-04xx	Current with different switching frequencies (I_{2N} at 50 °C)			
	2 kHz	4 kHz	8 kHz	12 kHz
1-phase $U_N = 200...240$ V				
02A4-1	2.4	2.4	1.9	1.6
03A7-1	3.7	3.7	2.9	2.4
04A8-1	4.8	4.8	3.9	3.3
06A9-1	6.9	6.9	5.6	4.7
07A8-1	7.8	7.8	6.6	5.8
09A8-1	9.8	9.8	8.3	7.2
12A2-1	12.2	12.2	10.0	8.4
3-phase $U_N = 200...240$ V				
02A4-2	2.4	2.4	2.0	1.8
03A7-2	3.7	3.7	3.1	2.7
04A8-2	4.8	4.8	4.0	3.1
06A9-2	6.9	6.9	5.8	4.5
07A8-2	7.8	7.8	6.4	4.7
09A8-2	9.8	9.8	8.1	5.9
12A2-2	12.2	12.2	10.3	7.7
17A5-2	17.5	17.5	14.8	11.0
25A0-2	25.0	25.0	20.7	15.1
032A-2	32.0	32.0	26.5	19.3
048A-2	48.0	48.0	35.8	23.7
055A-2	55.0	55.0	40.7	33.1
3-phase $U_N = 380...480$ V				
01A8-4	1.8	1.8	1.2	0.86
02A6-4	2.6	2.6	1.7	1.2
03A3-4	3.3	3.3	2.1	1.6
04A0-4	4.0	4.0	2.6	1.9
05A6-4	5.6	5.6	3.6	2.7
07A2-4	7.2	7.2	4.7	3.5
09A4-4	9.4	9.4	6.1	4.5
12A6-4	12.6	12.6	8.5	6.4
17A0-4	17.0	17.0	11.5	8.6
25A0-4	25.0	25.0	16.8	12.6
032A-4	32.0	32.0	21.7	16.7
038A-4	38.0	38.0	24.6	18.5
045A-4	45.0	45.0	29.4	21.9
050A-4	50.0	50.0	32.9	24.5

3AXD10000299801.xls

For frame R4: Keep the minimum switching frequency in its default value (parameter 97.02 = 1.5 kHz) if the application is cyclic and the ambient temperature is constantly over +40 °C. Adjusting the parameter decreases the product life time and/or limits the performance in the temperature range +40...60 °C.

■ Altitude derating

230 V units: 1000...2000 m above sea level, the derating is 1% for every 100 m (330 ft).

400 V units: 1000...4000 m above sea level, the derating is 1% for every 100 m (330 ft) Up to 4000 m altitude is possible for 400 V units when following boundary conditions are taken into account:

- Maximum switching voltage for integrated Relay Output 1 is 30 V at 4000 m altitude (e.g. it is not allowed to connect 250 V to Relay Output 1).
- When using BREL-01 side option module maximum potential difference between adjacent relays is 30 V (e.g. it is not allowed to connect 250 V to Relay Output 2 and 30 V to Relay Output 3).
- If the conditions are not met, the maximum altitude is 2000 m.
- When using 3-phase 400 V ACS380 drive at 4000 m altitude, you can connect the drive only to the following power systems: TN-S, TN-c, TN-CS, TT (not corner earthed).

To calculate the output current, multiply the current in the rating table with the derating factor k, which for x meters (1000 m ≤ x ≤ 4000 m) is:

$$k = 1 - \frac{1}{10\,000\text{ m}} \cdot (x - 1000)\text{ m}$$

Check the network compatibility restrictions above 1000 m (3281 ft). Check also PELV limitation on relay output terminals above 1000 m (3281 ft).

Fuses (IEC)

The table lists gG, UL, and uR or aR fuses for protection against short-circuit in the input power cable or drive. Either fuse type can be used if it operates rapidly enough. The operating time depends on the supply network impedance, and the cross-sectional area and length of the supply cable. Refer to [Implementing short-circuit protection](#) on page 56.

Do not use fuses with a higher current rating than given in the table.

You can use fuses from other manufacturers, if they meet the ratings, and if the melting curve of the fuse does not exceed the melting curve of the fuse mentioned in the table.

■ gG fuses

Make sure that the operating time of the fuse is less than 0.5 seconds. Obey the local regulations.

Type ACS380-04xx	Input current	Min. short- circuit current	Nominal current	I^2t	Voltage rating	ABB type	IEC 60269 size
	A	A	A	A ² s	V		
1-phase $U_N = 200...240$ V							
02A4-1	5.0	80	10	380	500	OFAF000H10	000
03A7-1	7.8	80	10	380	500	OFAF000H10	000
04A8-1	10.1	128	16	720	500	OFAF000H16	000
06A9-1	14.5	200	20	1500	500	OFAF000H20	000
07A8-1	16.4	200	25	2500	500	OFAF000H25	000
09A8-1	20.6	256	32	2500	500	OFAF000H32	000
12A2-1	25.6	320	35	7000	500	OFAF000H35	000
3-phase $U_N = 200...240$ V							
02A4-2	3.8	48	6	110	500	OFAF000H6	000
03A7-2	5.9	80	10	360	500	OFAF000H10	000
04A8-2	7.7	80	10	360	500	OFAF000H10	000
06A9-2	11.0	128	16	740	500	OFAF000H16	000
07A8-2	12.5	128	16	740	500	OFAF000H16	000
09A8-2	15.7	128	16	740	500	OFAF000H16	000
12A2-2	19.5	200	25	2500	500	OFAF000H25	000
17A5-2	28.0	256	32	4500	500	OFAF000H32	000
25A0-2	40.0	400	50	15500	500	OFAF000H50	000
032A-2	51.2	504	63	20000	500	OFAF000H63	000
048A-2	76.8	800	100	65000	500	OFAF000H100	000
055A-2	88.0	800	100	65000	500	OFAF000H100	000

94 Technical data

Type ACS380-04xx	Input current	Min. short- circuit current	Nominal current	I^2t	Voltage rating	ABB type	IEC 60269 size
	A	A	A	A^2s	V		
3-phase $U_N = 380...480$ V							
01A8-4	2.9	32	4	55	500	OFAF000H4	000
02A6-4	4.2	48	6	110	500	OFAF000H6	000
03A3-4	5.3	48	6	110	500	OFAF000H6	000
04A0-4	6.4	80	10	360	500	OFAF000H10	000
05A6-4	9.0	80	10	360	500	OFAF000H10	000
07A2-4	11.5	128	16	740	500	OFAF000H16	000
09A4-4	15.0	128	16	740	500	OFAF000H16	000
12A6-4	20.2	200	25	2500	500	OFAF000H25	000
17A0-4	27.2	256	32	4500	500	OFAF000H32	000
25A0-4	40.0	400	50	15500	500	OFAF000H50	000
032A-4	51.2	504	63	20000	500	OFAF000H63	000
038A-4	60.8	640	80	36000	500	OFAF000H80	000
045A-4	72.0	800	100	65000	500	OFAF000H100	000
050A-4	80.0	800	100	65000	500	OFAF000H100	000

3AXD10000299801.xls

■ UL fuses

Type ACS380-04xx	Input current	Min. short- circuit current	Nominal current	Voltage rating	Bussmann/ Edison type	Type
	A	A	A	V		
1-phase $U_N = 200...240$ V						
02A4-1	5.0	80	10	300	JJN/TJN10	UL class T
03A7-1	7.8	80	10	300	JJN/TJN10	UL class T
04A8-1	10.1	128	20	300	JJN/TJN20	UL class T
06A9-1	14.5	200	20	300	JJN/TJN20	UL class T
07A8-1	16.4	200	25	300	JJN/TJN25	UL class T
09A8-1	20.6	256	25	300	JJN/TJN25	UL class T
12A2-1	25.6	320	35	300	JJN/TJN35	UL class T
3-phase $U_N = 200...240$ V						
02A4-2	3.8	48	6	600	JJS/TJS6	UL class T
03A7-2	5.9	80	10	600	JJS/TJS10	UL class T
04A8-2	7.7	80	10	600	JJS/TJS10	UL class T
06A9-2	11.0	128	20	600	JJS/TJS20	UL class T
07A8-2	12.5	128	20	600	JJS/TJS20	UL class T
09A8-2	15.7	128	20	600	JJS/TJS20	UL class T
12A2-2	19.5	200	25	600	JJS/TJS25	UL class T
17A5-2	28.0	256	35	600	JJS/TJS35	UL class T
25A0-2	40.0	400	50	600	JJS/TJS50	UL class T
032A-2	51.2	504	60	600	JJS/TJS60	UL class T
048A-2	76.8	800	100	600	JJS/TJS100	UL class T
055A-2	88.0	800	100	600	JJS/TJS100	UL class T
3-phase $U_N = 380...480$ V						
01A8-4	2.9	32	6	600	JJS/TJS6	UL class T
02A6-4	4.2	48	6	600	JJS/TJS6	UL class T
03A3-4	5.3	48	6	600	JJS/TJS6	UL class T
04A0-4	6.4	80	10	600	JJS/TJS10	UL class T
05A6-4	9.0	80	10	600	JJS/TJS10	UL class T
07A2-4	11.5	128	20	600	JJS/TJS20	UL class T
09A4-4	15.0	128	20	600	JJS/TJS20	UL class T
12A6-4	20.2	200	25	600	JJS/TJS25	UL class T
17A0-4	27.2	256	35	600	JJS/TJS35	UL class T
25A0-4	40.0	400	50	600	JJS/TJS50	UL class T
032A-4	51.2	504	60	600	JJS/TJS60	UL class T
038A-4	60.8	640	80	600	JJS/TJS80	UL class T
045A-4	72.0	800	100	600	JJS/TJS100	UL class T
050A-4	80.0	800	100	600	JJS/TJS100	UL class T

■ gR fuses

Type ACS380-04xx	Input current	Min. short- circuit current	Nominal current	I ² t	Voltage rating	Bussmann type	IEC 60269 size
	A	A	A	A ² s	V		
1-phase U _N = 200...240 V							
02A4-1	5.0	80	32	275	690	170M2695	00
03A7-1	7.8	80	32	275	690	170M2695	00
04A8-1	10.1	128	40	490	690	170M2696	00
06A9-1	14.5	200	50	1000	690	170M2697	00
07A8-1	16.4	200	63	1800	690	170M2698	00
09A8-1	20.6	256	63	1800	690	170M2698	00
12A2-1	25.6	320	63	1800	690	170M2698	00
3-phase U _N = 200...240 V							
02A4-2	3.8	48	25	125	690	170M2694	00
03A7-2	5.9	80	32	275	690	170M2695	00
04A8-2	7.7	80	32	275	690	170M2695	00
06A9-2	11.0	128	40	490	690	170M2696	00
07A8-2	12.5	128	40	490	690	170M2696	00
09A8-2	15.7	128	40	490	690	170M2696	00
12A2-2	19.5	200	50	1000	690	170M2697	00
17A5-2	28.0	256	63	1800	690	170M2698	00
25A0-2	40.0	400	80	3600	690	170M2699	00
032A-2	51.2	504	100	6650	690	170M2700	00
048A-2	76.8	800	160	22500	690	170M2702	00
055A-2	88.0	800	160	22500	690	170M2702	00
3-phase U _N = 380...480 V							
01A8-4	2.9	32	25	125	690	170M2694	00
02A6-4	4.2	48	25	125	690	170M2694	00
03A3-4	5.3	48	25	125	690	170M2694	00
04A0-4	6.4	80	32	275	690	170M2695	00
05A6-4	9.0	80	32	275	690	170M2695	00
07A2-4	11.5	128	40	490	690	170M2696	00
09A4-4	15.0	128	40	490	690	170M2696	00
12A6-4	20.2	200	50	1000	690	170M2697	00
17A0-4	27.2	256	63	1800	690	170M2698	00
25A0-4	40.0	400	80	3600	690	170M2699	00
032A-4	51.2	504	100	6650	690	170M2700	00
038A-4	60.8	640	125	12000	690	170M2701	00
045A-4	72.0	800	160	22500	690	170M2702	00
050A-4	80.0	800	160	22500	690	170M2702	00

Alternate short-circuit protection

■ Miniature circuit breakers (IEC environment)

The protective characteristics of the circuit breakers depend on the type, construction and settings of the breakers. There are also limitations pertaining to the short-circuit capacity of the supply network. Your local ABB representative can help you in selecting the breaker type when the supply network characteristics are known.



WARNING! Due to the inherent operating principle and construction of circuit breakers, independent of the manufacturer, hot ionized gases can escape from the breaker enclosure in case of a short-circuit. To ensure safe use, pay special attention to the installation and placement of the breakers. Obey the manufacturer's instructions.

You can use the circuit breakers listed below. You can also use other circuit breakers with the drive if they provide the same electrical characteristics. ABB does not assume any liability whatsoever for the correct function and protection with circuit breakers not listed below. Furthermore, if the recommendations given by ABB are not obeyed, the drive can experience problems the warranty does not cover.

Note: Miniature circuit breakers with or without fuses have not been evaluated for use as short circuit protection in USA (UL) environments.

Type code 1-phase $U_N = 200...240\text{ V}$ (200, 208, 220, 230, 240 V)	Frame	ABB miniature circuit breaker		kA ¹⁾
		Type		
ACS380-04xx-02A4-1	R0	S 201P-B 10 NA		5
ACS380-04xx-03A7-1	R0	S 201P-B 10 NA		5
ACS380-04xx-04A8-1	R1	S 201P-B 16 NA		5
ACS380-04xx-06A9-1	R1	S 201P-B 20 NA		5
ACS380-04xx-07A8-1	R1	S 201P-B 25 NA		5
ACS380-04xx-09A8-1	R2	S 201P-B 25 NA		5
ACS380-04xx-12A2-1	R2	S 201P-B 32 NA		5
3-phase $U_N = 380...480\text{ V}$ (380, 400, 415, 440, 460, 480 V)				
ACS380-04xx-01A8-4	R0	S 203P-B 4		5
ACS380-04xx-02A6-4	R1	S 203P-B 6		5
ACS380-04xx-03A3-4	R1	S 203P-B 6		5
ACS380-04xx-04A0-4	R1	S 203P-B 8		5
ACS380-04xx-05A6-4	R1	S 203P-B 10		5
ACS380-04xx-07A2-4	R1	S 203P-B 16		5
ACS380-04xx-09A4-4	R1	S 203P-B 16		5
ACS380-04xx-12A6-4	R2	S 203P-B 25		5
ACS380-04xx-17A0-4	R3	S 203P-B 32		5
ACS380-04xx-25A0-4	R3	S 203P-B 50		5
ACS380-04xx-032A-4	R4	Contact ABB		
ACS380-04xx-038A-4	R4	Contact ABB		
ACS380-04xx-045A-4	R4	Contact ABB		
ACS380-04xx-050A-4	R4	Contact ABB		

1) Maximum allowed rated conditional short-circuit current (IEC 61800-5-1) of the electrical power network.

■ Self-protected combination manual controller – Type E USA (UL) environment

You can use the ABB Type E manual motor protectors MS132 & S1-M3-25, MS165-xx and MS5100-100 as an alternate to the recommended fuses as a means of branch circuit protection. This is in accordance with the National Electrical Code (NEC). When the correct ABB Type E manual motor protector is selected from the table and used for branch circuit protection, the drive is suitable for use in a circuit capable of delivering no more than 65 kA RMS symmetrical amperes at the drive's maximum rated voltage. See the following table for the appropriate ratings. See the MMP rating table for the minimum enclosure volume of IP20 open type ACS380 mounted in an enclosure.

Type code 1-phase $U_N = 200...240\text{ V}$ (200, 208, 220, 230, 240 V)	Frame	MMP type ^{1) 2)}	Minimum enclosure volume ⁵⁾	
			dm ³	cu in
ACS380-04xx-02A4-1	R0	MS132-6.3 & S1-M3-25 ³⁾	30.2	1842
ACS380-04xx-03A7-1	R0	MS132-10 & S1-M3-25 ³⁾	30.2	1842
ACS380-04xx-04A8-1	R1	MS165-16	30.2	1842
ACS380-04xx-06A9-1	R1	MS165-16	30.2	1842
ACS380-04xx-07A8-1	R1	MS165-20	30.2	1842
ACS380-04xx-09A8-1	R2	MS165-25	30.2	1842
ACS380-04xx-12A2-1	R2	MS165-32	30.2	1842
3-phase $U_N = 380...480\text{ V}$ (380, 400, 415, 440, 460, 480 V) ^{4) 5)}				
ACS380-04xx-01A8-4	R0	MS132-4.0 & S1-M3-25 ³⁾	30.2	1842
ACS380-04xx-02A6-4	R1	MS132-6.3 & S1-M3-25 ³⁾	30.2	1842
ACS380-04xx-03A3-4	R1	MS132-6.3 & S1-M3-25 ³⁾	30.2	1842
ACS380-04xx-04A0-4	R1	MS132-10 & S1-M3-25 ³⁾	30.2	1842
ACS380-04xx-05A6-4	R1	MS132-10 & S1-M3-25 ³⁾	30.2	1842
ACS380-04xx-07A2-4	R1	MS165-16	30.2	1842
ACS380-04xx-09A4-4	R1	MS165-16	30.2	1842
ACS380-04xx-12A6-4	R2	MS165-20	30.2	1842
ACS380-04xx-17A0-4	R3	MS165-32	30.2	1842
ACS380-04xx-25A0-4	R3	MS165-42	30.2	1842
ACS380-04xx-032A-4	R4	Contact ABB		
ACS380-04xx-038A-4	R4	Contact ABB		
ACS380-04xx-045A-4	R4	Contact ABB		
ACS380-04xx-050A-4	R4	Contact ABB		

1) All manual motor protectors listed are Type E self-protected up to 65 kA. See the ABB publication 2CDC131085M0201 – Manual Motor Starters – North American Applications for complete technical data on the ABB Type E manual motor protectors. In order for these manual motor protectors to be used for branch circuit protection, they must be UL listed Type E manual motor protectors, otherwise they can be used only as an At Motor Disconnect. "At Motor Disconnect" is a disconnect just ahead of the motor on the load side of the panel.

2) Manual motor protectors may require adjusting the trip limit from the factory setting at or above the drive input Amps to avoid nuisance tripping. If the manual motor protector is set to the maximum current trip level and nuisance tripping is occurring, select the next size MMP. (MS132-10 is the highest size in the MS132 frame size to meet Type E at 65 kA; the next size up is MS165-16.)

3) Requires the use of the S1-M3-25 line side feeder terminal with the manual motor protector to meet Type E self-protection class.

4) 480Y/277V delta systems only: Short-circuit protective devices with slash voltage ratings (e.g. 480Y/277 V AC) can be applied only in solidly grounded networks where the voltage from line-to-ground does not exceed the lower of the two ratings (e.g. 277 V AC), and the voltage from line-to-line does not exceed the higher of the two ratings (e.g. 480 V AC). The lower rating represents the device's interrupting capability per pole.

5) For all drives, the enclosure must be sized to accommodate the specific thermal considerations of the application as well as provide free space for cooling. See section [Free space requirements](#) on page 101. For UL only: The minimum enclosure volume is specified in the UL listing when applied with the ABB Type E MMP shown in the table. ACS380 drives are intended to be mounted in an enclosure, unless a NEMA-1 kit is added.

Dimensions and weights

Frame size	Dimensions and weights																	
	IP20 / UL type open																	
	H1		H2		H3		W		D1		D2		M1		M2		Weight	
	mm	in	mm	in	mm	in	mm	in	mm	in	mm	in	mm	in	mm	in	kg	lb
R0	205	8.07	220	8.66	170	6.69	70	2.76	174	6.85	191	7.52	50	1.97	191	7.52	1.4	3.1
R1	205	8.07	220	8.66	170	6.69	70	2.76	174	6.85	191	7.52	50	1.97	191	7.52	1.6	3.5
R2	205	8.07	220	8.66	170	6.69	95	3.74	174	6.85	191	7.52	75	2.95	191	7.52	1.9	4.2
R3	205	8.07	220	8.66	170	6.69	169	6.65	174	6.85	191	7.52	148	5.83	191	7.52	2.9	6.4
R4	205	8.07	220	8.66	170	6.69	260	10.24	174	6.85	191	7.52	238	9.37	191	7.52	5.8	12.7

3AXD10000299801.xls

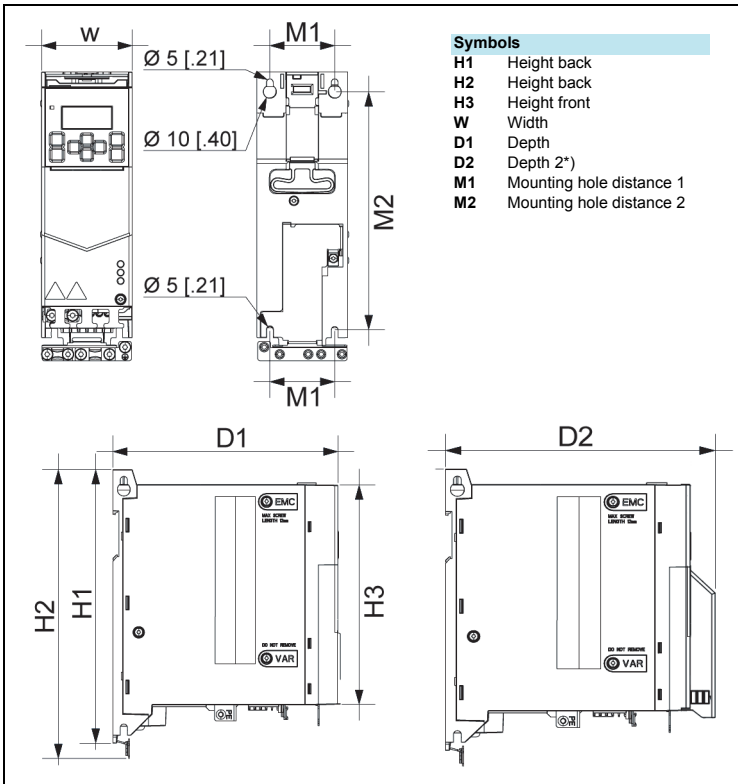

*) D2 = optional deeper cover

Free space requirements

Frame size	Free space requirement					
	Above		Below		On the sides ⁽¹⁾	
	mm	in	mm	in	mm	in
R0-R4	75	3	75	3	0	0

3AXD10000299801.xls

1) You can install the modules side by side, but if you plan to install side-mounted options, leave 20 mm of space to the right side of the module.

Losses, cooling data and noise

Frame size R0 has natural convection cooling. Frame sizes R1...R4 have a cooling fan. The air flow direction is from bottom to top.

The table below specifies the heat dissipation in the main circuit at nominal load and in the control circuit with minimum load (I/O and panel not in use) and maximum load (all digital inputs in the on state and the panel, fieldbus and fan in use). The total heat dissipation is the sum of the heat dissipation in the main and control circuits.

Type ACS380- 04xx	Heat dissipation				Air flow m ³ /h	Noise dB(A)	Frame size
	Main circuit at rated I_{1N} and I_{2N}	Control circuit minimum	Control circuit maximum	Main and control boards maximum			
	W	W	W	W			
1-phase $U_N = 200...240$ V							
02A4-1	32	7	18	51	-	< 30 dB	R0
03A7-1	46	7	18	65	-	< 30 dB	R0
04A8-1	59	9	20	80	57	63 dB	R1
06A9-1	85	9	20	105	57	63 dB	R1
07A8-1	95	9	20	115	57	63 dB	R1
09A8-1	115	9	20	135	63	59 dB	R2
12A2-1	145	9	20	165	63	59 dB	R2
3-phase $U_N = 200...240$ V							
02A4-2	19	9	20	39	57	63 dB	R1
03A7-2	26	9	20	46	57	63 dB	R1
04A8-2	35	9	20	55	57	63 dB	R1
06A9-2	42	9	20	62	57	63 dB	R1
07A8-2	50	9	20	70	57	63 dB	R1
09A8-2	68	9	20	88	57	63 dB	R1
12A2-2	87	9	20	107	63	59 dB	R2
17A5-2	116	11	22	138	128	66 dB	R3
25A0-2	160	11	22	182	128	66 dB	R3
032A-2	218	18	30	247	150	69 dB	R4
048A-2	319	18	30	349	150	69 dB	R4
055A-2	435	18	30	465	150	69 dB	R4
3-phase $U_N = 380...480$ V							
01A8-4	26	7	18	44	-	< 30 dB	R0
02A6-4	35	9	20	55	57	63 dB	R1
03A3-4	42	9	20	62	57	63 dB	R1

Type ACS380- 04xx	Heat dissipation				Air flow	Noise	Frame size
	Main circuit at rated I_{1N} and I_{2N}	Control circuit minimum	Control circuit maximum	Main and control boards maximum			
	W	W	W	W	m ³ /h	dB(A)	
04A0-4	50	9	20	70	57	63 dB	R1
05A6-4	68	9	20	88	57	63 dB	R1
07A2-4	88	9	20	108	57	63 dB	R1
09A4-4	115	9	20	135	57	63 dB	R1
12A6-4	158	9	20	178	63	59 dB	R2
17A0-4	208	11	22	230	128	66 dB	R3
25A0-4	322	11	22	344	128	66 dB	R3
032A-4	435	18	30	465	216	69 dB	R4
038A-4	537	18	30	566	216	69 dB	R4
045A-4	638	18	30	668	216	69 dB	R4
050A-4	709	18	30	668	216	69 dB	R4

3AXD10000299801.xls

Terminal data for the power cables

IEC

Type	U1, V1, W1 / U2, V2, W2 / BRK+, BRK- / DC+, DC- terminals						PE terminal	
	ACS380-04xx-		Min (solid/stranded)		Max (solid/stranded)		Torque	
	mm ²	AWG	mm ²	AWG	N·m	lbf·in	N·m	lbf·in
1-phase $U_N = 200...240$ V								
02A4-1	0.2/0.2	18	6/6	10	0.5...0.6	5	1.2	10.6
03A7-1	0.2/0.2	18	6/6	10	0.5...0.6	5	1.2	10.6
04A8-1	0.2/0.2	18	6/6	10	0.5...0.6	5	1.2	10.6
06A9-1	0.2/0.2	18	6/6	10	0.5...0.6	5	1.2	10.6
07A8-1	0.2/0.2	18	6/6	10	0.5...0.6	5	1.2	10.6
09A8-1	0.5/0.5	18	6/6	10	0.5...0.6	5	1.2	10.6
12A2-1	0.5/0.5	18	6/6	10	0.5...0.6	5	1.2	10.6
3-phase $U_N = 200...240$ VTBC								
02A4-2	0.2/0.2	18	6/6	8	0.5...0.6	5	1.2	10.6
03A7-2	0.2/0.2	18	6/6	8	0.5...0.6	5	1.2	10.6
04A8-2	0.2/0.2	18	6/6	8	0.5...0.6	5	1.2	10.6
06A9-2	0.2/0.2	18	6/6	8	0.5...0.6	5	1.2	10.6
07A8-2	0.2/0.2	18	6/6	8	0.5...0.6	5	1.2	10.6
09A8-2	0.2/0.2	18	6/6	8	0.5...0.6	5	1.2	10.6
12A2-2	0.2/0.2	24	6/6	10	0.5...0.6	5	1.2	10.6
17A5-2	0.5/0.5	20	16/16	6	1.2...1.5	11...13	1.2	10.6
25A0-2	0.5/0.5	20	16/16	6	1.2...1.5	11...13	1.2	10.6
032A-2	0.5/0.5	20	25/35	2	2.5...3.7	22...32	2.9	25.7
048A-2	0.5/0.5	20	25/35	2	2.5...3.7	22...32	2.9	25.7
055A-2	0.5/0.5	20	25/35	2	2.5...3.7	22...32	2.9	25.7
3-phase $U_N = 380...480$ V								
01A8-4	0.2/0.2	18	6/6	10	0.5...0.6	5	1.2	10.6
02A6-4	0.2/0.2	18	6/6	10	0.5...0.6	5	1.2	10.6
03A3-4	0.2/0.2	18	6/6	10	0.5...0.6	5	1.2	10.6
04A0-4	0.2/0.2	18	6/6	10	0.5...0.6	5	1.2	10.6
05A6-4	0.2/0.2	18	6/6	10	0.5...0.6	5	1.2	10.6
07A2-4	0.2/0.2	18	6/6	10	0.5...0.6	5	1.2	10.6
09A4-4	0.2/0.2	18	6/6	10	0.5...0.6	5	1.2	10.6
12A6-4	0.2/0.2	18	6/6	10	0.5...0.6	5	1.2	10.6
17A0-4	0.5/0.5	20	16/16	6	1.2...1.5	11...13	1.2	10.6
25A0-4	0.5/0.5	20	16/16	6	1.2...1.5	11...13	1.2	10.6
032A-4	0.5/0.5	20	16/16	6	2.5...3.7	22...32	2.9	25.7
038A-4	0.5/0.5	20	25/35	2	2.5...3.7	22...32	2.9	25.7
045A-4	0.5/0.5	20	25/35	2	2.5...3.7	22...32	2.9	25.7
050A-4	0.5/0.5	20	25/35	2	2.5...3.7	22...32	2.9	25.7

Terminal data for the control cables

Type ACS380-04xx-	All control cables			
	Wire size		Torque	
	mm ²	AWG	N·m	lbf·in
1-phase $U_N = 200...240$ V				
02A4-1	0.14...1.5	26...16	0.5...0.6	4.4...5.3
03A7-1	0.14...1.5	26...16	0.5...0.6	4.4...5.3
04A8-1	0.14...1.5	26...16	0.5...0.6	4.4...5.3
06A9-1	0.14...1.5	26...16	0.5...0.6	4.4...5.3
07A8-1	0.14...1.5	26...16	0.5...0.6	4.4...5.3
09A8-1	0.14...1.5	26...16	0.5...0.6	4.4...5.3
12A2-1	0.14...1.5	26...16	0.5...0.6	4.4...5.3
3-phase $U_N = 200...240$ V				
02A4-2	0.14...1.5	26...16	0.5...0.6	4.4...5.3
03A7-2	0.14...1.5	26...16	0.5...0.6	4.4...5.3
04A8-2	0.14...1.5	26...16	0.5...0.6	4.4...5.3
06A9-2	0.14...1.5	26...16	0.5...0.6	4.4...5.3
07A8-2	0.14...1.5	26...16	0.5...0.6	4.4...5.3
09A8-2	0.14...1.5	26...16	0.5...0.6	4.4...5.3
12A2-2	0.14...1.5	26...16	0.5...0.6	4.4...5.3
17A5-2	0.14...1.5	26...16	0.5...0.6	4.4...5.3
25A0-2	0.14...1.5	26...16	0.5...0.6	4.4...5.3
032A-2	0.14...1.5	26...16	0.5...0.6	4.4...5.3
048A-2	0.14...1.5	26...16	0.5...0.6	4.4...5.3
055A-2	0.14...1.5	26...16	0.5...0.6	4.4...5.3
3-phase $U_N = 380...480$ V				
01A8-4	0.14...1.5	26...16	0.5...0.6	4.4...5.3
02A6-4	0.14...1.5	26...16	0.5...0.6	4.4...5.3
03A3-4	0.14...1.5	26...16	0.5...0.6	4.4...5.3
04A0-4	0.14...1.5	26...16	0.5...0.6	4.4...5.3
05A6-4	0.14...1.5	26...16	0.5...0.6	4.4...5.3
07A2-4	0.14...1.5	26...16	0.5...0.6	4.4...5.3
09A4-4	0.14...1.5	26...16	0.5...0.6	4.4...5.3
12A6-4	0.14...1.5	26...16	0.5...0.6	4.4...5.3
17A0-4	0.14...1.5	26...16	0.5...0.6	4.4...5.3
25A0-4	0.14...1.5	26...16	0.5...0.6	4.4...5.3
032A-4	0.14...1.5	26...16	0.5...0.6	4.4...5.3
038A-4	0.14...1.5	26...16	0.5...0.6	4.4...5.3
045A-4	0.14...1.5	26...16	0.5...0.6	4.4...5.3
050A-4	0.14...1.5	26...16	0.5...0.6	4.4...5.3

External EMC filters

To comply with EMC limits in the European EMC Directive (standard IEC/EN 61800-3) with longer maximum motor cable lengths, use an external EMC filter. The table shows the EMC category that is met with the external EMC filter. For information on the maximum permitted motor cable length, refer to [Motor cable length](#) on page 107.

Type ACS380-04xx-	EMC filter type		Category		
	ABB order code	Schaffner order code	C1	C2	C3
1-phase $U_N = 200...240$ V					
02A4-1	RFI-11	FN 21754-6.1-07	x	x	x
03A7-1	RFI-12	FN 21754-16.1-07	x	x	x
04A8-1	RFI-12	FN 21754-16.1-07	x	x	x
06A9-1	RFI-12	FN 21754-16.1-07	x	x	x
07A8-1	N/A	N/A	-	-	-
09A8-1	N/A	N/A	-	-	-
12A2-1	N/A	N/A	-	-	-
3-phase $U_N = 380...480$ V					
01A8-4	RFI-32	FN 3268-16-44	x	x	x
02A6-4	RFI-32	FN 3268-16-44	x	x	x
03A3-4	RFI-32	FN 3268-16-44	x	x	x
04A0-4	RFI-32	FN 3268-16-44	x	x	x
05A6-4	RFI-32	FN 3268-16-44	x	x	x
07A2-4	RFI-32	FN 3268-16-44	x	x	x
09A4-4	RFI-32	FN 3268-16-44	x	x	x
12A6-4	RFI-33	FN 3268-30-33	x	x	x
17A0-4	RFI-33	FN 3268-30-33	x	x	x
25A0-4	RFI-34	FN 3258-100-35	x	x	x
032A-4	RFI-34	FN 3258-100-35		x	x
038A-4	RFI-34	FN 3258-100-35		x	x
045A-4	RFI-34	FN 3258-100-35		x	x
050A-4	RFI-34	FN 3258-100-35		x	x

3AXD10000299801.xls

To use an external EMC filter, remove the EMC screw. Refer to [EMC filter disconnection](#) on page 57.

Electric power network specification

Voltage (U_1) 200/208/220/230/240 V AC 1-phase for 200 V AC drives
 200/208/220/230/240 V AC 3-phase for 200 V AC drives
 380/400/415/440/460/480 V AC 3-phase for 400 V AC drives
 +10%/-15% variation from converter nominal voltage is allowed as default.

Network type Public low-voltage networks. TN (grounded), IT (ungrounded) and corner-grounded TN systems.

Rated conditional short-circuit current (IEC 61800-5-1) 65 kA when protected by fuses given in the fuse tables.

Short-circuit current protection (UL 61800-5-1, CSA C22.2 No. 274-13) US and Canada: The drive is suitable for use on a circuit capable of delivering not more than 100 kA symmetrical amperes (rms) at 480 V maximum when protected by fuses given in the fuse table.

Mains choke Use a mains choke if the short-circuit capacity of the network at the drive terminals is more than in the table:

Frame size/ Voltage rating	R0, R1, R2	R3, R4
1-phase 230 V	>5.0 kA	>7.5 kA
3-phase 230 V	>5.0 kA	>7.5 kA
3-phase 380...480 V	>5.0 kA	>10 kA

You can use one choke for several drives if the short-circuit capacity at the drive terminals is reduced to the value in the table.

Frequency (f1) 47 to 63 Hz, maximum rate of change 17%/s

Imbalance Max. $\pm 3\%$ of nominal phase to phase input voltage

Fundamental power factor (cos phi) 0.98 (at nominal load)

Motor connection data

Motor type	Asynchronous induction motor or permanent magnet synchronous motor
Voltage (U_2)	0 to U_1 , 3-phase symmetrical, U_{\max} at the field weakening point
Short-circuit protection (IEC 61800-5-1, UL 61800-5-1)	The motor output is short-circuit proof by IEC 61800-5-1 and UL 61800-5-1.
Frequency (f2)	0...599 Hz
Frequency resolution	0.01 Hz
Current	See <i> Ratings </i> on page 88.
Switching frequency	2, 4, 8 or 12 kHz

■ Motor cable length

Operational functionality and motor cable length

The drive is designed to operate with optimum performance with the following maximum motor cable lengths. The motor cable lengths may be extended with output chokes as shown in the table.

Frame size	Maximum motor cable length	
	m	ft
Standard drive, without external options		
R0	150	492
R1, R2	150	492
R3, R4	150	492
With external output chokes		
R0	60	195
R1...R3	250	820
R4	200	656

Note: In multimotor systems, the calculated sum of all motor cable lengths must not exceed the maximum motor cable length given in the table.

EMC compatibility and motor cable length

To comply with the EMC limits in the European EMC Directive (standard IEC/EN 61800-3), use these maximum motor cable lengths for the 4 kHz switching frequency.

Frame size	Maximum motor cable length, 4 kHz					
	C1		C2		C3	
	m	ft	m	ft	m	ft
With internal EMC filter (ACS380-042x)						
1-phase 208...240 V						
R0	-	-	10	30	30	100
R1	-	-	10	30	30	100
R2	-	-	10	30	30	100
3-phase 380...480 V						
R0	-	-	10	30	30	100
R1	-	-	10	30	30	100
R2	-	-	10	30	20	66
R3	-	-	10	30	30	100
R4	-	-	10	30	30	100
With optional external EMC filter						
1-phase 208...240 V						
R0	10	100	50	150	50	150
R1	10	100	50	150	50	150
R2	-	-	50	150	50	150
3-phase 208...240 V/380...480 V						
R0	30	100	50	150	50	150
R1	30	100	50	150	50	150
R2	30	100	50	150	50	150
R3	30	100	50	150	50	150
R4	-	-	30	100	50	150

1) Category C1 with conducted emissions only. Radiated emissions are not compatible when measured with the standard emission measurement setup and must be measured on cabinet and machine installations for each case.

Notes:

- Remove the EMC screw to disconnect the internal EMC filter. Refer to [EMC filter disconnection](#) on page 57.
- Radiated emissions are according to C2 with ACS380-042x drives. For ACS380-040x drives, use a metal enclosure to fulfill radiated emissions C2 limits with an external EMC filter.
- For 3-phase 380...400 V drives, the maximum motor cable lengths are according to C3 in the above table with an internal EMC filter.
- For 1-phase and 3-phase 208...240 V drives, the maximum motor cable lengths are according to the motor cable length table on page 107. The EMC category for these drives is C4 (no EMC).

Control connection data

Analog inputs (AI1, AI2)	Voltage signal, single-ended	0...10 V DC (10% overrange, 11 V DC max.) $R_{in} = 221.6 \text{ kohm}$		
	Current signal, single-ended	0...20 mA (10% overrange, 22 mA max.) $R_{in} = 137 \text{ ohm}$		
	Inaccuracy	$\leq 1.0\%$, of full scale		
	Overvoltage protection	up to 30 V DC		
	Potentiometer reference value	10 V DC $\pm 1\%$, max. load current 10 mA		
	Analog output (AO)	Current output mode	0...20 mA (10% overrange, 22 mA max.) into 500 ohm load	
Voltage output mode		0...10 V DC (10% overrange, 11 V DC max.) into 200 kohm minimum load (resistive)		
Inaccuracy		$\leq 1.0\%$, of full scale		
Auxiliary voltage input/output (+24V)	As output	+24 V DC $\pm 10\%$, max. 200 mA		
	As input	+24 V DC $\pm 10\%$, max. 1000 mA (incl internal fan load)		
Digital inputs (DI1...DI4)	Voltage	12...24 V DC (int. or ext. supply) Max. 30 V DC.		
	Type	PNP and NPN		
	Input impedance	$R_{in} = 2 \text{ kohm}$		
Programmable digital I/O (DIO1, DIO2)	As inputs	Voltage	12...24 V DC with internal or external supply. Max. 30 V DC.	
		Type	PNP and NPN	
		Input impedance	$R_{in} = 2 \text{ kohm}$	
	As outputs	Type	Transistor output PNP	
		Max. switching voltage	30 V DC	
		Max. switching current	70 mA / 30 V DC, short-circuit protected	
		Frequency	10 Hz...16 kHz	
		Resolution	1 Hz	
		Relay output (RA, RB, RC)	Type	1 From C (NO + NC)
			Max. switching voltage	250 V AC / 30 V DC
Max. switching current	2 A			
Frequency input (FI)	10 Hz...16 kHz	DI3 and DI4 can be used as digital or frequency inputs.		
Frequency output (FO)	DIO1 and DIO2 can be used as digital or frequency outputs.			
STO interface (SGND, S+, S1, S2)	Refer to Safe torque off function on page 139.			

Brake resistor connection

Short-circuit protection (IEC 61800-5-1, IEC 60439-1, UL 61800-5-1) The brake resistor output is conditionally short-circuit proof by IEC/EN 61800-5-1 and UL 61800-5-1. For correct fuse selection, contact your local ABB representative. Rated conditional short-circuit current as defined in IEC 60439-1.

Efficiency

Approximately 98% at nominal power level.

Degrees of protection

Degree of protection (IEC/EN 60529) IP20 (cabinet installation) / UL Open Type: Standard enclosure. The drive must be installed in a cabinet to fulfill the requirements for shielding from contact.

Enclosure types (UL 61800-5-1) UL Open Type. For indoor use only.

Overvoltage category (IEC 60664-1) III

Protective classes (IEC/EN 61800-5-1) I

Ambient conditions

Environmental limits for the drive are given below. The drive is to be used in a heated indoor controlled environment.

	Operation installed for stationary use	Storage in the protective package	Transportation in the protective package
Installation site altitude	<p>230 V units: 0 to 2000 m above sea level (with derating above 1000 m)</p> <p>400 V units: 0 to 4000 m above sea level (with derating above 1000 m)</p> <p>For more information, refer to page 92.</p>	-	-
Surrounding air temperature	<p>-10...+60 °C (14...140 °F)¹</p> <p>No frost allowed. Refer to <i>Derating</i> on page 90.</p> <p>1) For frame R0, -10...+50 °C (14...122 °F).</p>	-40...+70 °C ±2% (-40...+158 °F ±2%)	-40...+70 °C ±2% (-40...+158 °F ±2%)
Relative humidity	0...95%	Max. 95%	Max. 95%
No condensation allowed. Maximum allowed relative humidity is 60% in the presence of corrosive gases.			
Contamination levels (IEC 60721-3-3, IEC 60721-3-2, IEC 60721-3-1)	No conductive dust allowed.		
	<p>According to IEC 60721-3-3, chemical gases: Class 3C2 solid particles: Class 3S2.</p> <p>Install the drive according to the enclosure classification.</p> <p>Make sure that the cooling air is clean, and free from corrosive materials and electrically conductive dust.</p>	<p>According to IEC 60721-3-1, chemical gases: Class 1C2 solid particles: Class 1S2</p>	<p>According to IEC 60721-3-2, chemical gases: Class 2C2 solid particles: Class 2S2</p>
Pollution degree (IEC/EN 61800-5-1)	Pollution degree 2	-	-

Sinusoidal vibration (IEC 60721-3-3)	Tested according to IEC 60721-3-3, mechanical conditions: Class 3M4 2...9 Hz, 3.0 mm (0.12 in) 9...200 Hz, 10 m/s ² (33 ft/s ²)	-	-
Shock (IEC 60068-2-27, ISTA 1A)	Not allowed	According to ISTA 1A. Max. 100 m/s ² (330 ft/s ²), 11 ms.	According to ISTA 1A. Max. 100 m/s ² (330 ft/s ²), 11 ms.
Free fall	Not allowed	76 cm (30 in)	76 cm (30 in)

Materials

Drive enclosure

- PC/ABS 2 mm, PC+10%GF 2.5...3 mm and PA66+25%GF 1.5 mm, all in color NCS 1502-Y (RAL 9002 / PMS 420 C)
- Hot-dip zinc coated steel sheet 1.5 mm, thickness of coating 20 micrometers
- Extruded aluminum AlSi

Package

Corrugated cardboard.

Disposal

The main parts of the drive can be recycled to preserve natural resources and energy. Product parts and materials should be dismantled and separated.

Generally all metals, such as steel, aluminum, copper and its alloys, and precious metals can be recycled as material. Plastics, rubber, cardboard and other packaging material can be used in energy recovery. Printed circuit boards and DC capacitors (C1-1 to C1-x) need selective treatment according to IEC 62635 guidelines. To aid recycling, plastic parts are marked with an appropriate identification code.

Contact your local ABB distributor for further information on environmental aspects and recycling instructions for professional recyclers. End of life treatment must follow international and local regulations.

Applicable standards

The drive complies with the following standards:

EN ISO 13849-1:2015

Safety of machinery – Safety related parts of the control systems – Part 1: general principles for design

EN ISO 13849-2:2012

Safety of machinery – Safety-related parts of the control systems – Part 2: Validation

EN 60204-1:2006 +
A1:2009 + AC:2010

Safety of machinery. Electrical equipment of machines. Part 1: General requirements. *Provisions for compliance:* The final assembler of the machine is responsible for installing
- an emergency-stop device
- a supply disconnecting device

EN 62061:2005 + AC:2010 + A1:2013 + A2:2015	Safety of machinery – Functional safety of safety-related electrical, electronic and programmable electronic control systems
EN 61800-3:2004 + A1:2012 IEC 61800-3:2004 + A1:2011	Adjustable speed electrical power drive systems. Part 3: EMC requirements and specific test methods
IEC/EN 61800-5-1:2007	Adjustable speed electrical power drive systems – Part 5-1: Safety requirements – Electrical, thermal and energy
ANSI/UL 61800-5- 1:2015	UL Standard for adjustable speed electrical power drive systems – Part 5-1: Safety requirements – Electrical, thermal and energy
CSA C22.2 No. 274-13	Adjustable speed drives

CE marking

A CE mark is attached to the drive to verify that the drive follows the provisions of the European Low Voltage, EMC, RoHS and WEEE Directives. The CE marking also verifies that the drive, in regard to its safety functions (such as Safe torque off), conforms with the Machinery Directive as a safety component.

■ Compliance with the European Low Voltage Directive

The compliance with the European Low Voltage Directive has been verified according to standard EN 61800-5-1:2007. Declaration is available on the Internet.

■ Compliance with the European EMC Directive

The EMC Directive defines the requirements for immunity and emissions of electrical equipment used within the European Union. The EMC product standard (EN 61800-3:2004 + A1:2012) covers requirements stated for drives. Refer to [Compliance with EN 61800-3:2004 + A1:2012](#) on page 115. The declaration is available on the Internet.

■ Compliance with the European RoHS Directive

The RoHS Directive defines the restriction of the use of certain hazardous substances in electrical and electronic equipment. The declaration is available on the Internet.

■ Compliance with the European WEEE Directive

The WEEE Directive defines the regulated disposal and recycling of electric and electrical equipment.

■ Compliance with the European Machinery Directive

The drive includes the Safe torque off function and can be equipped with other safety functions for machinery which, as safety components, are in the scope of the Machinery Directive. These functions of the drive comply with European harmonized standards such as EN 61800-5-2. Refer to [Safe torque off function](#) on page 139.

Power and productivity
for a better world™



EU Declaration of Conformity

Low Voltage Directive 2014/35/EU and EMC Directive 2014/30/EU

We

Manufacturer: ABB Oy
Address: Hiomotie 13, 00380 Helsinki, Finland.
Phone: +358 10 22 11

declare under our sole responsibility that the following product

Frequency converter

ACS380-04xx (frames R0 – R2, 1ph 200 - 240Vac)

ACS380-04xx (frames R0 – R4, 3ph 380 - 480Vac)

ACS380-04xx (frames R1 – R4, 3ph 200 – 240Vac)

is in conformity with the relevant requirements of Low Voltage Directive 2014/35/EU and EMC Directive 2014/30/EU, provided that the equipment is selected, installed and used according to given instructions.

The following harmonized standards have been applied:

EN 61800-5-1:2007

*Adjustable speed electrical power drive systems - Part 5-1:
Safety requirements - Electrical, thermal and energy*

EN 61800-3:2004 + A1:2012

*Adjustable speed electrical power drive systems - Part 3: EMC requirements and
specific test methods*

The product referred in this Declaration of conformity fulfils the relevant provisions of other European Union Directives which are notified in Single EU Declaration of conformity 3AXD10000495941.

Helsinki, 23rd March 2018

Manufacturer representative:

Vesa Kandell
Vice President, ABB Oy



Compliance with EN 61800-3:2004 + A1:2012

■ Definitions

EMC stands for **E**lectromagnetic **C**ompatibility. It is the ability of electrical/electronic equipment to operate without problems within an electromagnetic environment. Likewise, the equipment must not disturb or interfere with any other product or system within its locality.

First environment includes establishments connected to a low-voltage network which supplies buildings used for domestic purposes.

Second environment includes establishments connected to a network not directly supplying domestic premises.

Drive of category C1: drive of rated voltage less than 1000 V and intended for use in the first environment.

Drive of category C2: drive of rated voltage less than 1000 V and intended to be installed and started up only by an authorised professional when used in the first environment.

Drive of category C3: drive of rated voltage less than 1000 V, intended for use in the second environment and not intended for use in the first environment.

■ Category C1

The conducted emission limits are complied with the following provisions:

1. The optional EMC filter is selected according to the ABB documentation and installed as specified in the EMC filter manual.
2. The motor and control cables are selected as specified in this manual.
3. The drive is installed according to the instructions given in this manual.
4. For the maximum motor cable length with 4 kHz switching frequency, refer to [Motor cable length](#) on page 107.

In a domestic environment, this product can cause radio-frequency interference, in which case supplementary mitigation measures may be required.

■ Category C2

Applicable to ACS380-042x with an internal EMC C2 filter.

The emission limits are complied with the following provisions:

1. The motor and control cables are selected as specified in this manual.
 2. The drive is installed according to the instructions given in this manual.
 3. For the maximum motor cable length with 4 kHz switching frequency, refer to [Motor cable length](#) on page 107.
-

If it is used in a residential or domestic environment, the drive can cause radio-frequency interference. If it is necessary, take measures to prevent interference, in addition to the requirements for the CE compliance.



WARNING! Do not install a drive with the internal EMC filter connected on IT (ungrounded). The supply network becomes connected to ground potential through the internal EMC filter capacitors which may cause danger or damage to the drive. To disconnect the EMC filter, refer to [EMC filter disconnection](#) on page 63.



WARNING! Do not install a drive with internal EMC filter connected on corner-grounded TN systems; otherwise the drive will be damaged. To disconnect the EMC filter, refer to [EMC filter disconnection](#) on page 63.

■ Category C3

This is applicable to ACS380-040x-4/-2 drives with an internal EMC C3 filter.

The drive complies with the standard with the following provisions:

1. The motor and control cables are selected as specified in this manual.
2. The drive is installed according to the instructions given in this manual.
3. For the maximum motor cable length with 4 kHz switching frequency, refer to [Motor cable length](#) on page 107.



WARNING! To prevent radio-frequency interference, do not use a category C3 drive on a low-voltage public network which supplies domestic premises.

■ Category C4

This is applicable to ACS380-040x-1 drives.

If the provisions in Category C2 or C3 are not met, the requirements of the standard can be met as follows:

1. It is ensured that no excessive emission is propagated to neighboring low-voltage networks. In some cases, the inherent suppression in transformers and cables is sufficient. If in doubt, the supply transformer with static screening between the primary and secondary windings can be used.

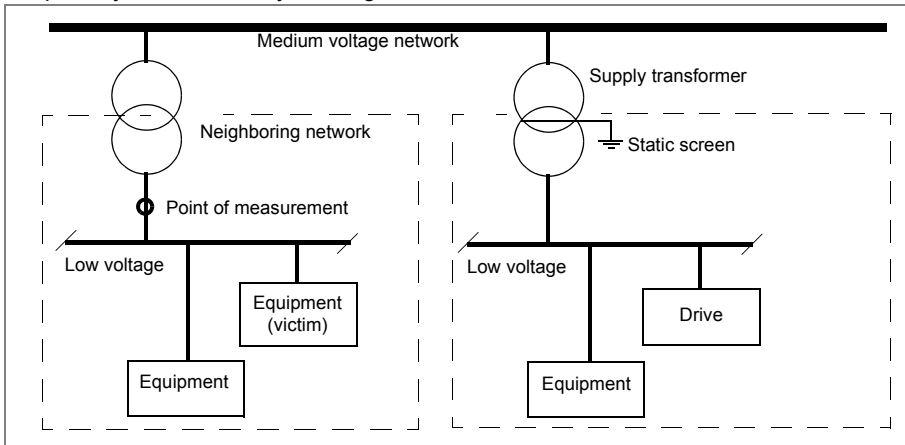

2. An EMC plan for preventing disturbances is drawn up for the installation. A template is available from the local ABB representative.
3. The motor and control cables are selected as specified in this manual.
4. The drive is installed according to the instructions given in this manual.



WARNING! To prevent radio-frequency interference, do not use a category C4 drive on a low-voltage public network which supplies domestic premises.

UL marking

■ UL checklist

- Make sure that the drive type designation label includes the cULus Listed marking.
- **CAUTION - Risk of electric shock.** After disconnecting the input power, always wait for 5 minutes to let the intermediate circuit capacitors discharge before you start working on the drive, motor or motor cable.
- The drive is to be used in a heated, indoor controlled environment. The drive must be installed in clean air according to the enclosure classification. Cooling air must be clean, free from corrosive materials and electrically conductive dust.
- The maximum ambient air temperature is 50 °C (122 °F) at rated current. Except for the R0 frame size, the current is derated for 50 to 60 °C (122 to 140 °F).
- The drive is suitable for use in a circuit capable of delivering not more than 100,000 rms symmetrical amperes, 480 V (or 240 V) maximum when protected by the UL fuses given in the table on page 95. The ampere rating is based on tests done according to the appropriate UL standard.
- The cables located within the motor circuit must be rated for at least 75 °C (167 °F) in UL-compliant installations.
- Integral solid state short circuit protection does not provide branch circuit protection. The input cable must be protected with fuses. Suitable IEC fuses are listed on page 93 and UL classified fuses on page 95. These fuses provide branch circuit protection in accordance with the National Electrical Code (NEC) and Canadian Electrical Code. For installation in the United States, also obey any other applicable local codes. For installation in Canada, also obey any applicable provincial codes.
Note: Circuit breakers must not be used without fuses in the USA. Contact your local representative for suitable circuit breakers.
- The drive provides motor overload protection. For the adjustments, refer to the firmware manual.
- For drive overvoltage category, refer to page 110. For pollution degree, see page 111.

RCM marking

Drive has RCM marking.

EAC marking

Drive has EAC marking.



China RoHS marking

The *People's Republic of China Electronic Industry Standard* (SJ/T 11364-2014) specifies the marking requirements for hazardous substances in electronic and electrical products. The green mark is attached to the drive to verify that it does not contain toxic and hazardous substances or elements above the maximum concentration values, and that it is an environmentally-friendly product which can be recycled and reused.

Disclaimers

■ Generic disclaimer

The manufacturer shall have no obligation hereunder with respect to any product which (i) has been improperly repaired or altered; (ii) has been subjected to misuse, negligence or accident; (iii) has been used in a manner contrary to the Manufacturer's instructions; or (iv) has failed as a result of ordinary wear and tear.

■ Cyber security disclaimer

This product is designed to be connected to and to communicate information and data via a network interface. It is Customer's sole responsibility to provide and continuously ensure a secure connection between the product and Customer network or any other network (as the case may be). Customer shall establish and maintain any appropriate measures (such as but not limited to the installation of firewalls, application of authentication measures, encryption of data, installation of anti-virus programs, etc) to protect the product, the network, its system and the interface against any kind of security breaches, unauthorized access, interference, intrusion, leakage and/or theft of data or information. ABB and its affiliates are not liable for damages and/or losses related to such security breaches, any unauthorized access, interference, intrusion, leakage and/or theft of data or information.



Dimension drawings

The dimension drawings of ACS380 drive frame sizes R0, R1, R2, R3 and R4. The dimensions are in millimeters and inches.

Note! Drives with the BIO-01 I/O extension module are supplied with a high cover part (part no) that increases the depth of the drive by 15 mm (0.6 in.).

Frame R0 (1-phase 230 V)

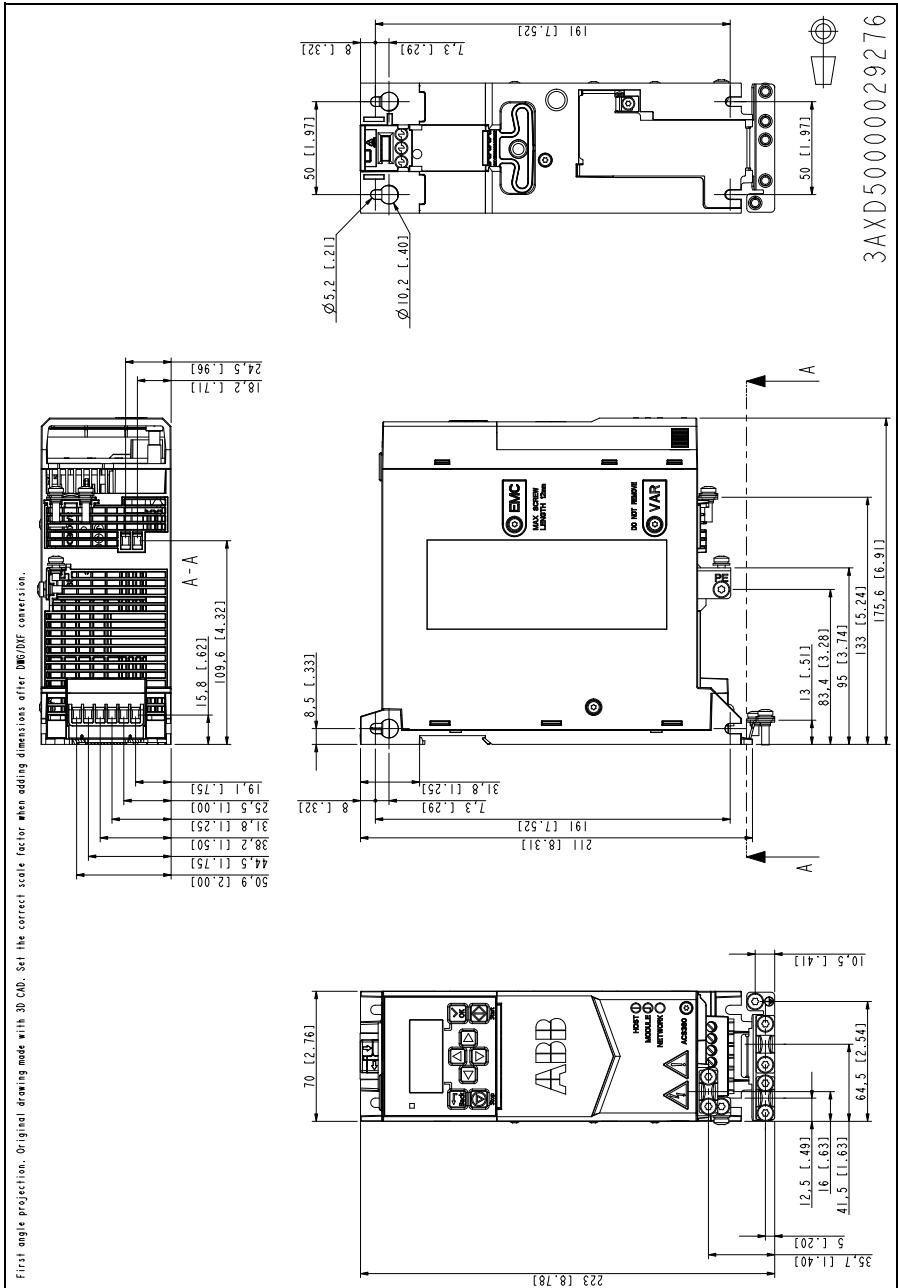

Frame R0 (400 V)

First angle projection. Original drawing made with 3D CAD. Set the correct scale factor when adding dimensions after DWG/DXF conversion.

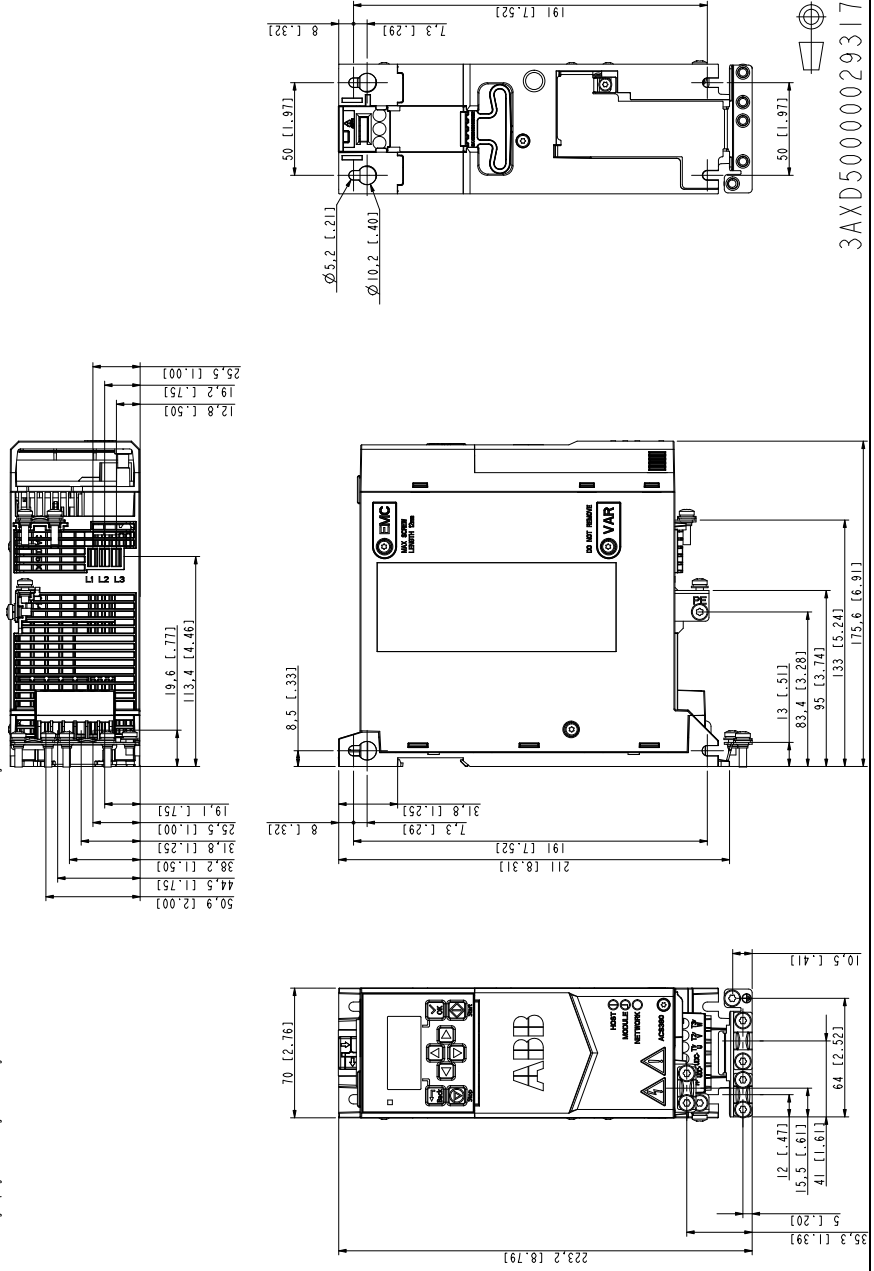

3AXD50000029317

Frame R1 (230 V)

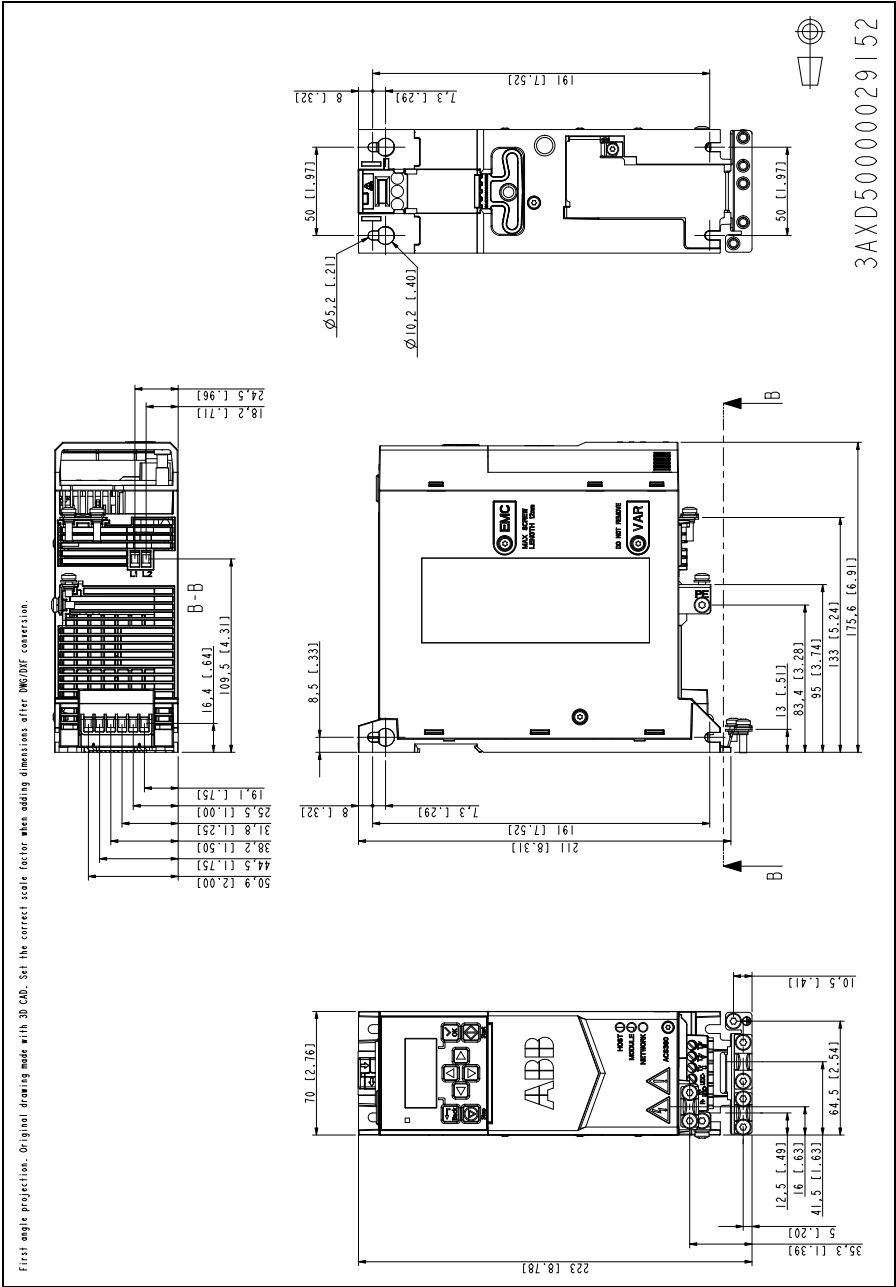

Frame R1 (3-phase 230 V and 3-phase 400 V)

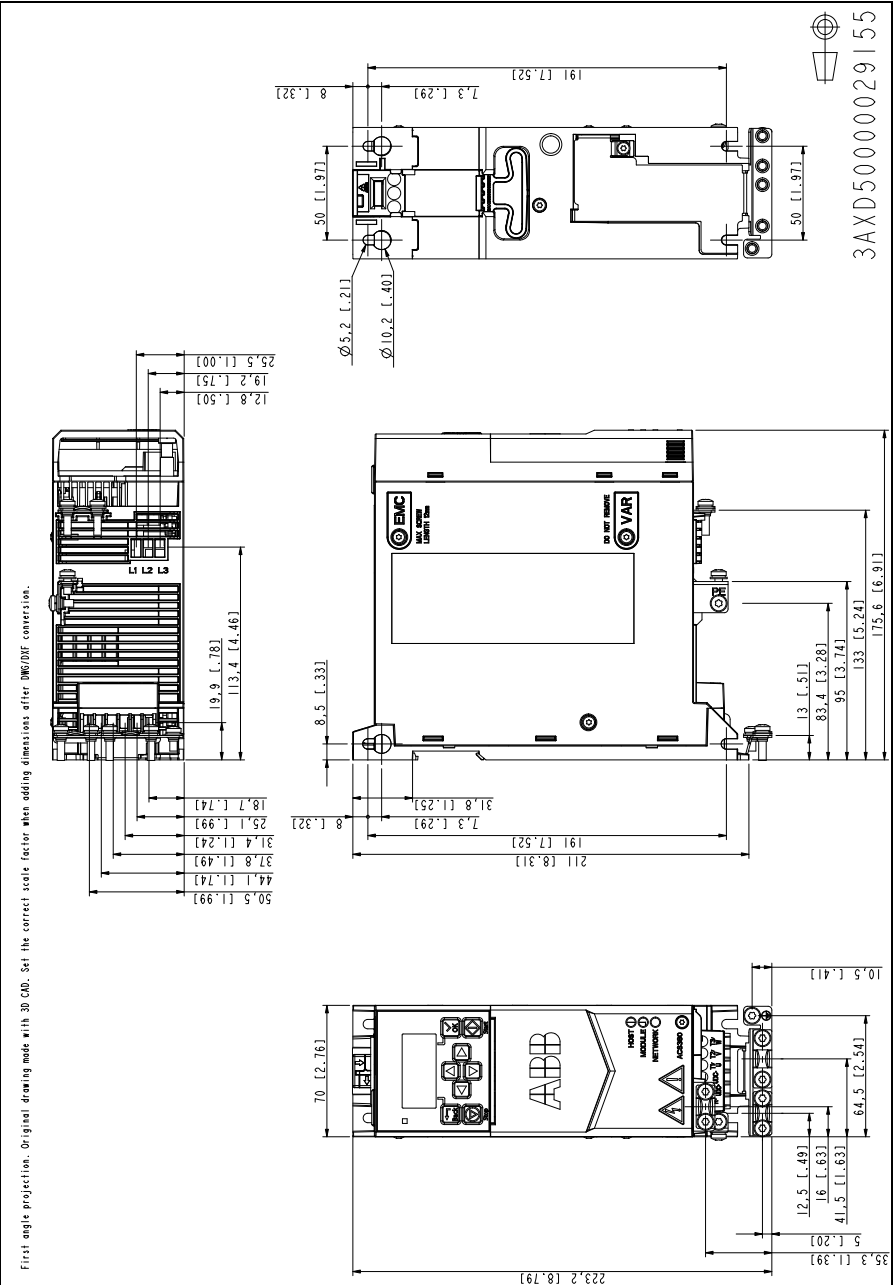

Frame R2 (230 V)

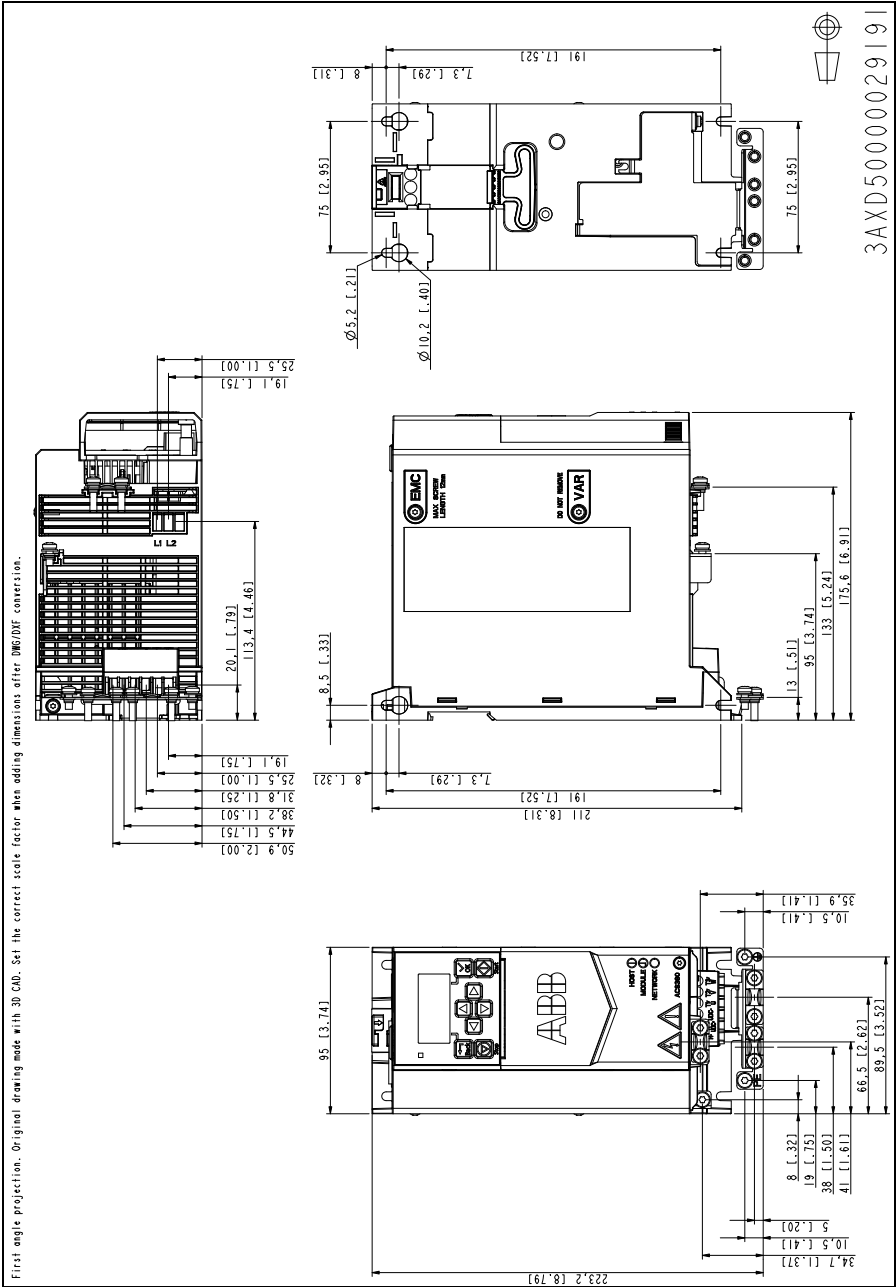

Frame R2 (400 V)

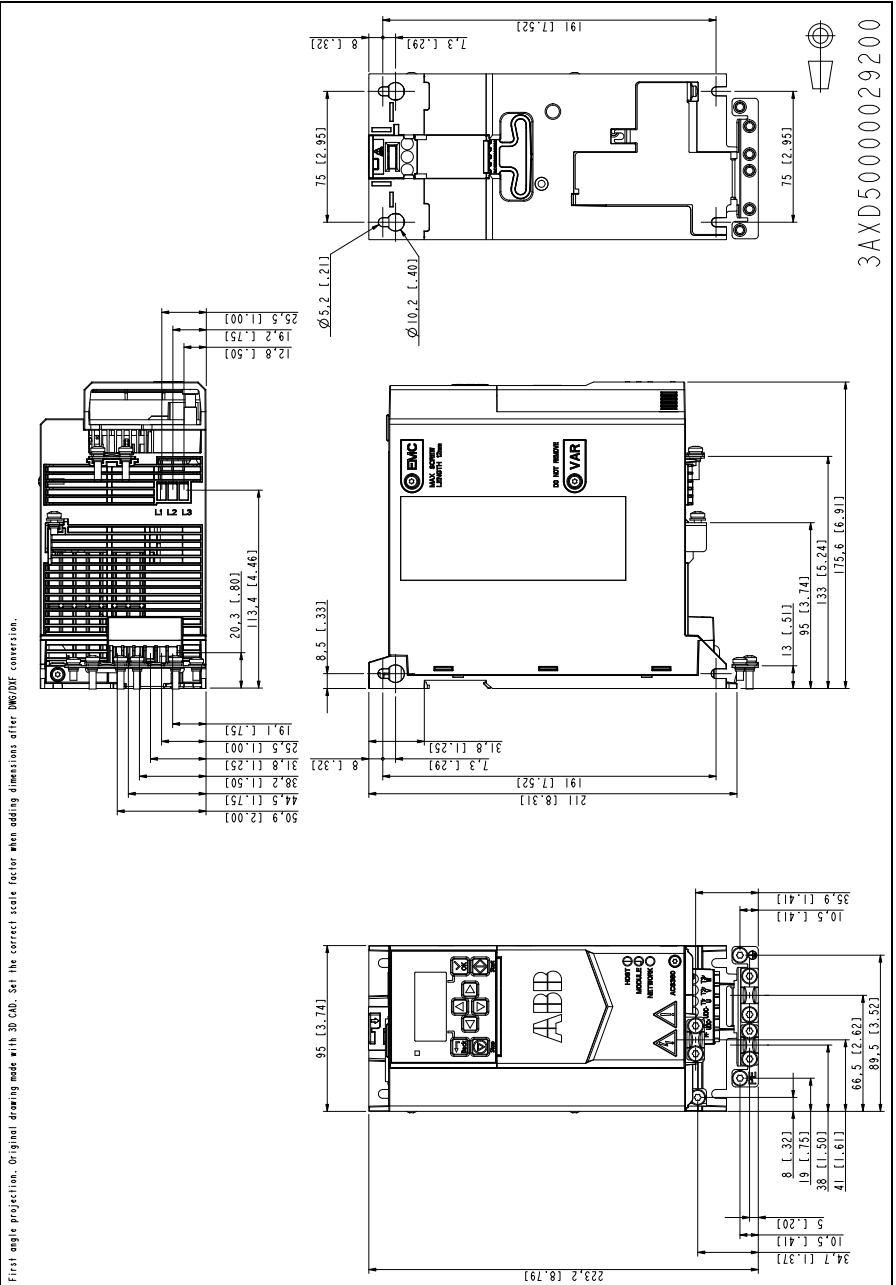

First angle projection. Original drawing made with 3D CAD. Set the correct scale factor when adding dimensions after DWG/DXF conversion.

Frame R3 (400 V)

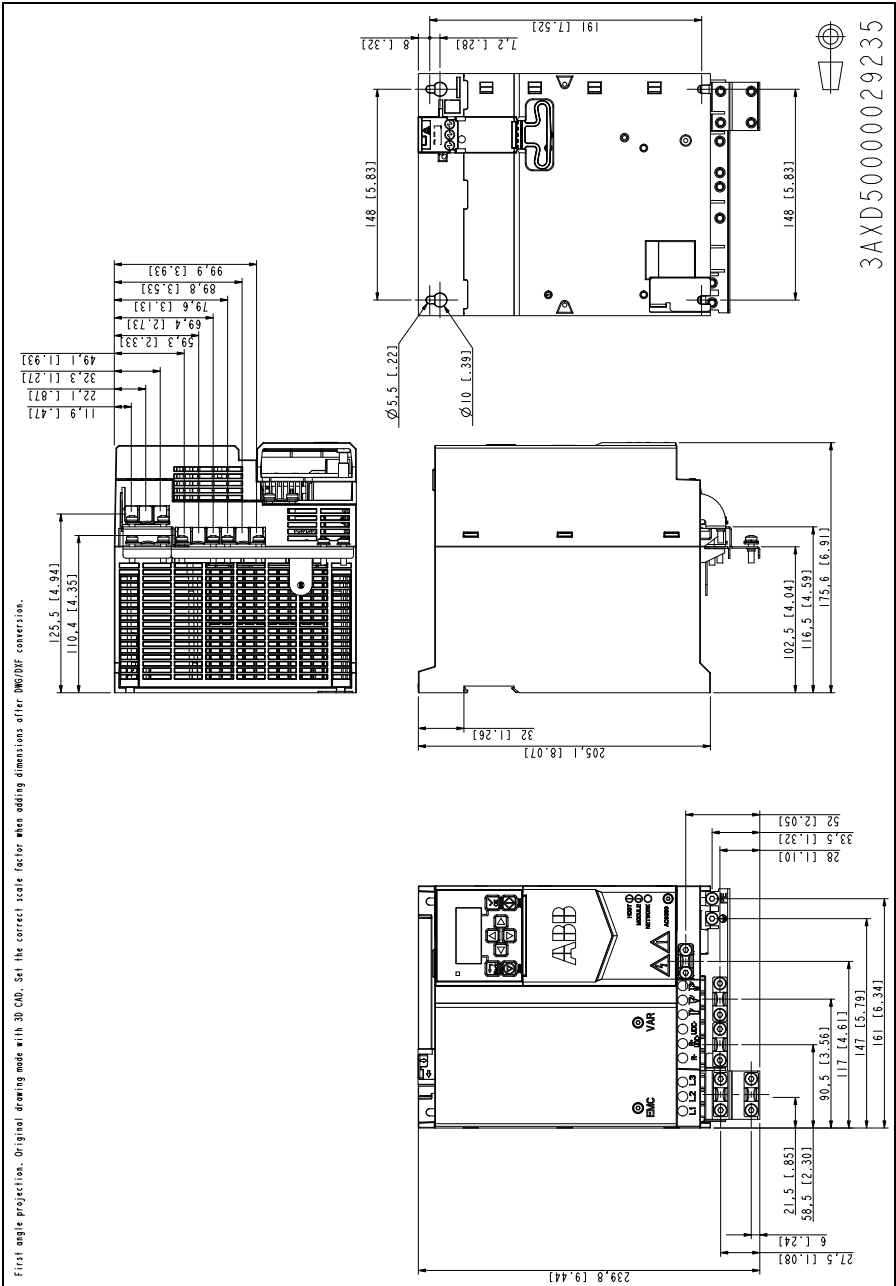

Frame R4 (400 V)

First angle projection. Original drawing made with 3D CAD. Set the correct scale factor when adding dimensions after DWG/DXF conversion.

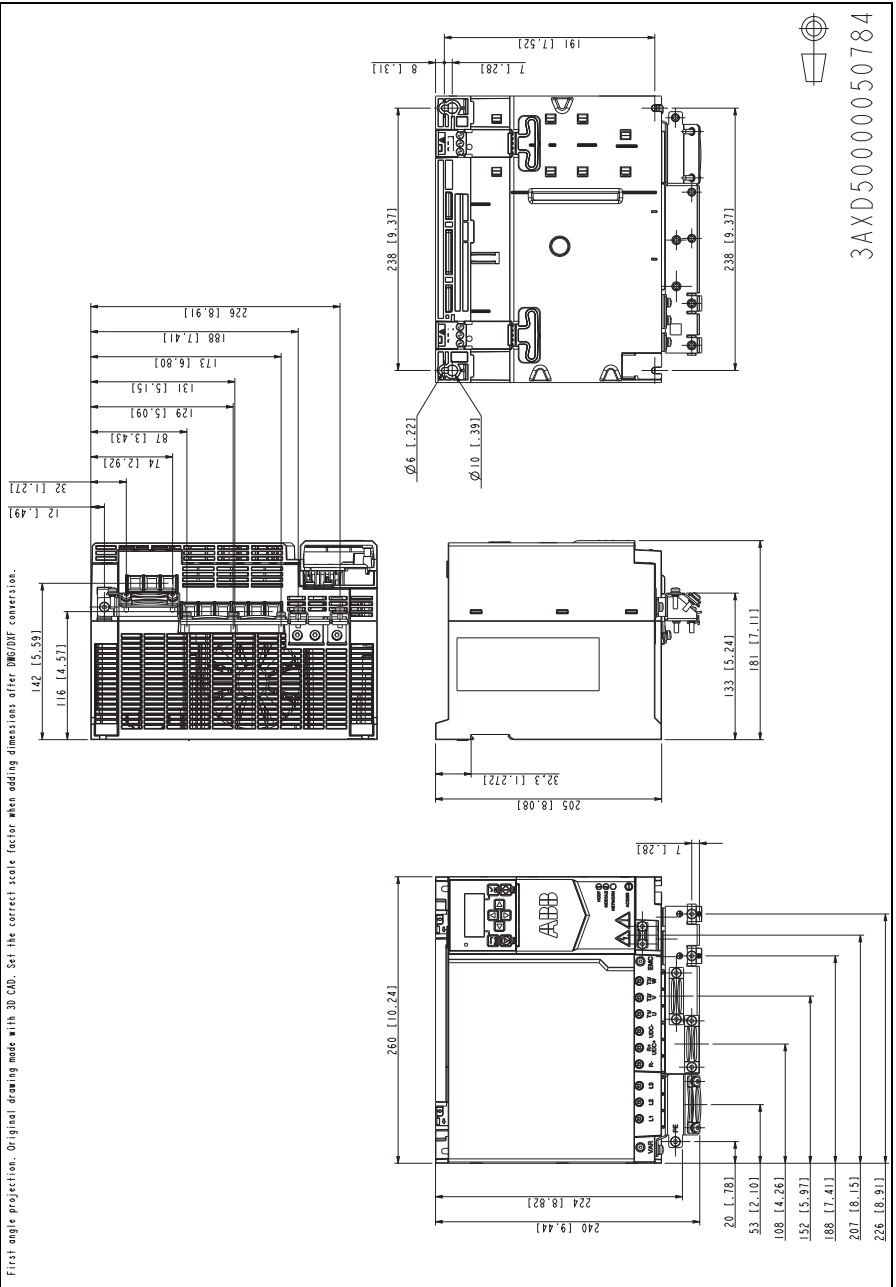



11

Resistor braking

Contents of this chapter

The chapter describes how to select the brake resistor and cables, protect the system, connect the brake resistor and enable resistor braking.

Operation principle and hardware description

The brake chopper handles the energy generated by a decelerating motor. The chopper connects the brake resistor to the intermediate DC circuit whenever the voltage in the circuit exceeds the limit defined by the control program. Energy consumption by the resistor losses lowers the voltage until the resistor can be disconnected.

Selecting the brake resistor

Drives have in built-in brake chopper as standard equipment. The brake resistor is selected using the table and equations presented in this section.

1. Determine the required maximum braking power $P_{R_{\max}}$ for the application. $P_{R_{\max}}$ must be smaller than $P_{BR_{\max}}$ given in the table on page 133 for the used drive type.
 2. Calculate resistance R with Equation 1.
 3. Calculate energy $E_{R_{\text{pulse}}}$ with Equation 2.
 4. Select the resistor so that the following conditions are met:
 - The rated power of the resistor must be greater than or equal to $P_{R_{\max}}$.
 - Resistance R must be between R_{\min} and R_{\max} given in the table for the used drive type.
 - The resistor must be able to dissipate energy $E_{R_{\text{pulse}}}$ during the braking cycle T .
-

Equations for selecting the resistor:

$$\text{Eq. 1. } U_N = 200 \dots 240 \text{ V: } R = \frac{150000}{P_{R\max}}$$

$$U_N = 380 \dots 415 \text{ V: } R = \frac{450000}{P_{R\max}}$$

$$U_N = 415 \dots 480 \text{ V: } R = \frac{615000}{P_{R\max}}$$

$$\text{Eq. 2. } E_{R\text{pulse}} = P_{R\max} \cdot t_{\text{on}}$$

$$\text{Eq. 3. } P_{R\text{ave}} = P_{R\max} \cdot \frac{t_{\text{on}}}{T}$$

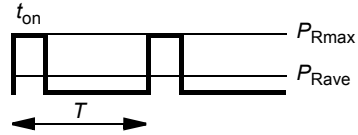

For conversion, use 1 hp = 746 W.

where

R = calculated brake resistor value (ohm). Make sure that: $R_{\min} < R < R_{\max}$.

$P_{R\max}$ = maximum power during the braking cycle (W)

$P_{R\text{ave}}$ = average power during the braking cycle (W)

$E_{R\text{pulse}}$ = energy conducted into the resistor during a single braking pulse (J)

t_{on} = length of the braking pulse (s)

T = length of the braking cycle (s).



WARNING! Do not use a brake resistor with a resistance below the minimum value specified for the particular drive. The drive and the internal chopper are not able to handle the overcurrent caused by the low resistance.

Reference brake resistors

Type ACS380- 04xx	R_{min}	R_{max}	P_{BRcont}		P_{BRmax}		Reference resistor types	Braking time ⁽¹⁾
	ohm	ohm	kW	hp	kW	hp		
1-phase $U_N = 200...240$ V								
02A4-1	32.5	468	0.25	0.33	0.38	0.50	CBH 360 C T 406 210R or CAR 200 D T 406 210R	Refer to braking resistor manufacturer's documentation
03A7-1	32.5	316	0.37	0.50	0.56	0.74		
04A8-1	32.5	213	0.55	0.75	0.83	1.10		
06A9-1	32.5	145	0.75	1.00	1.10	1.50	CBR-V 330 D T 406 78R UL	
07A8-1	32.5	96.5	1.10	1.50	1.70	2.20	CBR-V 560 D HT 406 39R UL	
09A8-1	32.5	69.9	1.50	2.00	2.30	3.00		
12A2-1	19.5	47.1	2.20	3.00	3.30	4.40		
3-phase $U_N = 200...240$ V								
02A4-2	39	474	0.25	0.33	0.38	0.50	CBH 360 C T 406 210R or CAR 200 D T 406 210R	Refer to braking resistor manufacturer's documentation
03A7-2	39	319	0.37	0.50	0.56	0.74		
04A8-2	39	217	0.55	0.75	0.83	1.10		
06A9-2	39	145	0.75	1.00	1.13	1.50	CBR-V 330 D T 406 78R UL	
07A8-2	39	105	1.10	1.50	1.65	2.20	CBR-V 560 D HT 406 39R UL	
09A8-2	20	71	1.50	2.00	2.25	3.00		
12A2-2	20	52	2.20	2.00	3.30	4.40		
17A5-2	16	38	3.00	3.00	4.50	6.00	CBT-H 560 D HT 406 19R	
25A0-2	16	28	4.00	5.00	6.00	8.00	CBT-V 760 G H T 282 8R	
032A-2	3	20	5.50	7.50	8.25	11.00		
048A-2	3	14	7.50	10.00	11.25	15.00		
055A-2	3	10	11.00	15.00	16.50	21.99		
3-phase $U_N = 380...480$ V								
01A8-4	99	933	0.37	0.50	0.56	0.74	CBH 360 C T 406 210R or CAR 200 D T 406 210R	Refer to braking resistor manufacturer's documentation
02A6-4	99	628	0.55	0.75	0.83	1.10		
03A3-4	99	428	0.75	1.00	1.13	1.50		
04A0-4	99	285	1.10	1.50	1.65	2.20		
05A6-4	99	206	1.50	2.00	2.25	3.00	CBR-V 330 D T 406 78R UL	
07A2-4	53	139	2.20	2.00	3.30	4.40		
09A4-4	53	102	3.00	3.00	4.50	6.00		
12A6-4	32	76	4.00	5.00	6.00	8.00	CBR-V 560 D HT 406 39R UL	
17A0-4	32	54	5.50	7.50	8.25	11.00		
25A0-4	23	39	7.50	10.00	11.25	15.00		
032A-4	6	29	11.00	15.00	17	22.00		
038A-4	6	24	15.00	20.00	23	30.00	CBT-H 760 D HT 406 16R	
045A-4	6	20	18.50	25.00	28	37.00	CBT-H 760 D HT 406 16R	
050A-4	6	20	22.00	30.00	33	44.00		

3AXD10000299801.xls

1) The maximum permitted braking cycle of the braking resistor differs from the that of the drive.

P_{BRmax} – The maximum braking capacity of the drive 1/10min ($P_{BRcont} * 150\%$), must exceed the desired braking power.

P_{BRcont} – The maximum braking capacity of the drive, must exceed the desired braking power.

R_{max} – The maximum resistance value that can provide P_{BRcont} . The resistance of the brake resistor can be smaller if the application allows it.

Selecting and routing the brake resistor cables

Use a shielded cable specified in section [Terminal data for the power cables](#) on page 103.

■ Minimizing electromagnetic interference

Follow these rules in order to minimize electromagnetic interference caused by the rapid current changes in the resistor cables:

- Install the cables away from other cable routes.
- Avoid long parallel runs with other cables. The minimum parallel cabling separation distance should be 0.3 meters.
- Cross the other cables at right angles.
- Keep the cable as short as possible in order to minimize the radiated emissions and stress on chopper IGBTs. The longer the cable the higher the radiated emissions, inductive load and voltage peaks over the IGBT semiconductors of the brake chopper.

■ Maximum cable length

The maximum length of the resistor cable(s) is 10 m (33 ft).

■ EMC compliance of the complete installation

ABB has not verified that the EMC requirements are fulfilled with external user-defined brake resistors and cabling. The EMC compliance of the complete installation must be considered by the customer.

Placing the brake resistor

Install the resistors outside the drive in a place where they will cool.

Arrange the cooling of the resistor in a way that:

- There is no danger of overheating to the resistor or nearby materials.
- The surrounding air temperature does not exceed the allowed maximum.

Supply the resistor with cooling air/water according to the resistor manufacturer's instructions.



WARNING! The materials near the brake resistor must be non-flammable. The surface temperature of the resistor is high. Air flowing from the resistor is of hundreds of degrees Celsius. If the exhaust vents are connected to a ventilation system, ensure that the material withstands high temperatures. Protect the resistor against physical contact.

Protecting the system in brake circuit fault situations

■ Protecting the system in cable and brake resistor short-circuit situations

The input fuses will also protect the resistor cable when it is identical with the input cable.

■ Protecting the system against thermal overload

Equipping the drive with a main contactor is highly recommended for safety reasons. Wire the contactor so that it opens in case the resistor overheats. This is essential for safety since the drive will not otherwise be able to interrupt the main supply if the chopper remains conductive in a fault situation. An example wiring diagram is shown below. ABB recommends that you use resistors equipped with a thermal switch (1) inside the resistor assembly. The switch indicates overtemperature and overload.

ABB recommends that you also wire the thermal switch to a digital input of the drive.

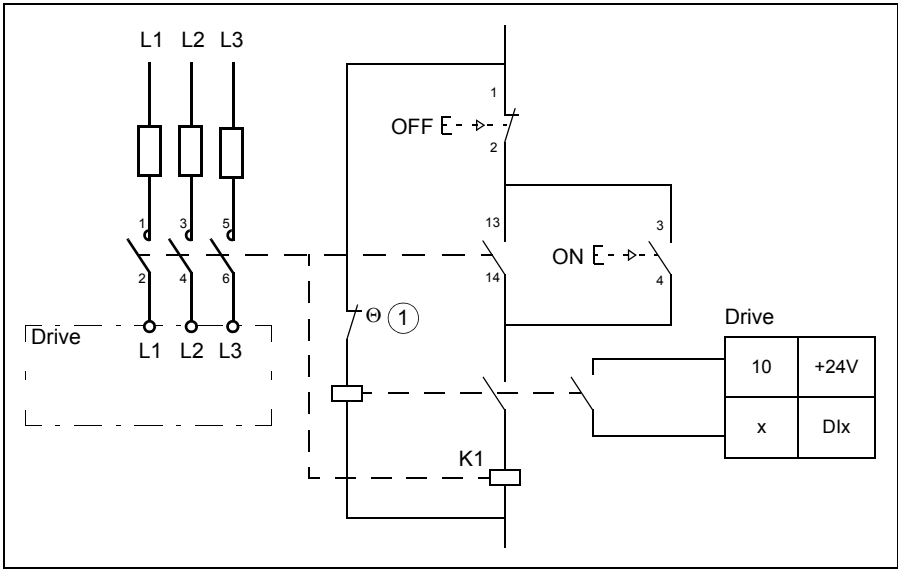

Mechanical installation

Refer to the resistor manufacturer's instructions.

Electrical installation

■ Checking the insulation of the assembly

Follow the instructions given in section [Brake resistor assembly](#) on page [Brake resistor assembly](#).

■ Connection diagram

See section [Connecting the power cables](#) on page [65](#).

■ Connection procedure

See section [Connecting the power cables](#) on page [65](#).

Connect the thermal switch of the brake resistor as described in section [Protecting the system against thermal overload](#) on page [135](#).

Start-up

Set the following parameters:

1. Disable the overvoltage control of the drive with parameter 30.30 Overvoltage control.
2. Set the source of parameter 31.01 External event 1 source to point to the digital input where the thermal switch of the brake resistor is wired.
3. Set parameter 31.02 External event 1 type to Fault.
4. Enable the brake chopper by parameter 43.06 Brake chopper enable. If Enabled with thermal model is selected, set also the brake resistor overload protection parameters 43.08 and 43.09 according to the application.
5. Check the resistance value of parameter 43.10 Brake resistance.

With these parameter settings, the drive generates a fault and coasts to a stop on brake resistor overtemperature.



WARNING! Disconnect the braking resistor, if it not enabled in the parameter settings.



Safe torque off function

Contents of this chapter

This chapter describes the Safe torque off (STO) function of the drive and gives instructions for its use.

Description

The Safe torque off function can be used, for example, as the final actuator device of safety circuits that stop the inverter in case of danger (such as an emergency stop circuit). Another typical application is a prevention of unexpected start-up function that enables short-time maintenance operations like cleaning or work on non-electrical parts of the machinery without switching off the power supply to the inverter.

Note: The Safe torque off function does not disconnect the voltage from the drive, see the warning on page [146](#).

When activated, the Safe torque off function disables the control voltage of the power semiconductors of the drive output stage (A, see diagram on page [142](#)), thus preventing the drive from generating the torque required to rotate the motor. If the motor is running when Safe torque off is activated, it coasts to a stop.

The Safe torque off function has a redundant architecture, that is, both channels must be used in the safety function implementation. The safety data given in this manual is calculated for redundant use, and does not apply if both channels are not used.

The Safe torque off function of the drive complies with these standards:

Standard	Name
IEC 60204-1:2016 EN 60204-1:2006 + A1:2009 + AC:2010	<i>Safety of machinery – Electrical equipment of machines – Part 1: General requirements</i>
IEC 61000-6-7:2014	<i>Electromagnetic compatibility (EMC) – Part 6-7: Generic standards – Immunity requirements for equipment intended to perform functions in a safety-related system (functional safety) in industrial locations</i>
IEC/EN 61326-3-1:2017	<i>Electrical equipment for measurement, control and laboratory use – EMC requirements – Part 3-1: Immunity requirements for safety-related systems and for equipment intended to perform safety-related functions (functional safety) – General industrial applications</i>
IEC 61508-1:2010	<i>Functional safety of electrical/electronic/programmable electronic safety-related systems – Part 1: General requirements</i>
IEC 61508-2:2010	<i>Functional safety of electrical/electronic/programmable electronic safety-related systems – Part 2: Requirements for electrical/electronic/programmable electronic safety-related systems</i>
IEC 61511-1:2016	<i>Functional safety – Safety instrumented systems for the process industry sector</i>
IEC 61800-5-2:2016 EN 61800-5-2:2007	<i>Adjustable speed electrical power drive systems – Part 5-2: Safety requirements – Functional</i>
IEC 62061:2015 EN 62061:2005 + AC:2010 + A1:2013 + A2:2015	<i>Safety of machinery – Functional safety of safety-related electrical, electronic and programmable electronic control systems</i>
EN ISO 13849-1:2015	<i>Safety of machinery – Safety-related parts of control systems – Part 1: General principles for design</i>
EN ISO 13849-2:2012	<i>Safety of machinery – Safety-related parts of control systems – Part 2: Validation</i>

The function also corresponds to Prevention of unexpected start-up as specified by EN 1037:1995 + A1:2008 and Uncontrolled stop (stop category 0) as specified in EN 60204-1:2006 + A1:2009 + AC:2010.

■ Compliance with the European Machinery Directive

See section [Compliance with the European Machinery Directive](#) on page 114.

Connection principle

■ Connection with internal +24 V DC power supply

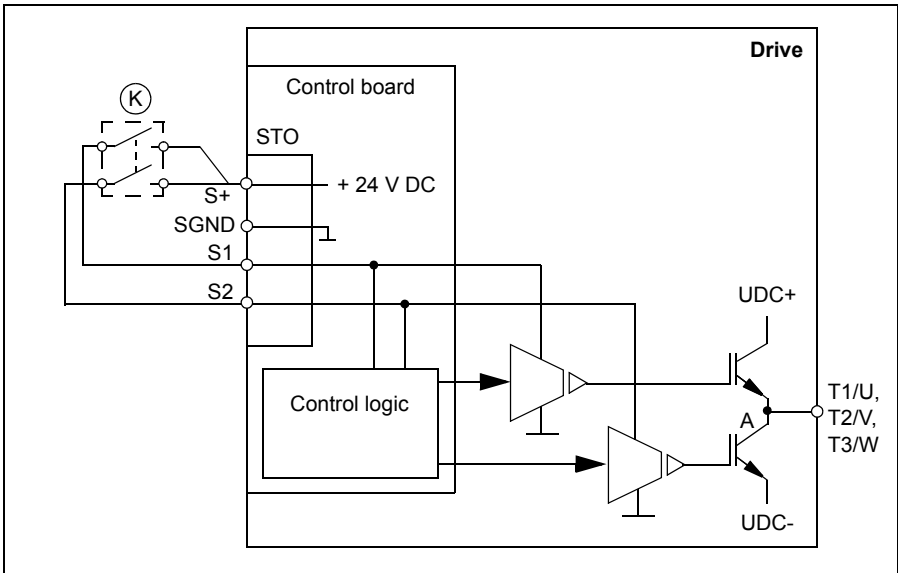

■ Connection with external +24 V DC power supply

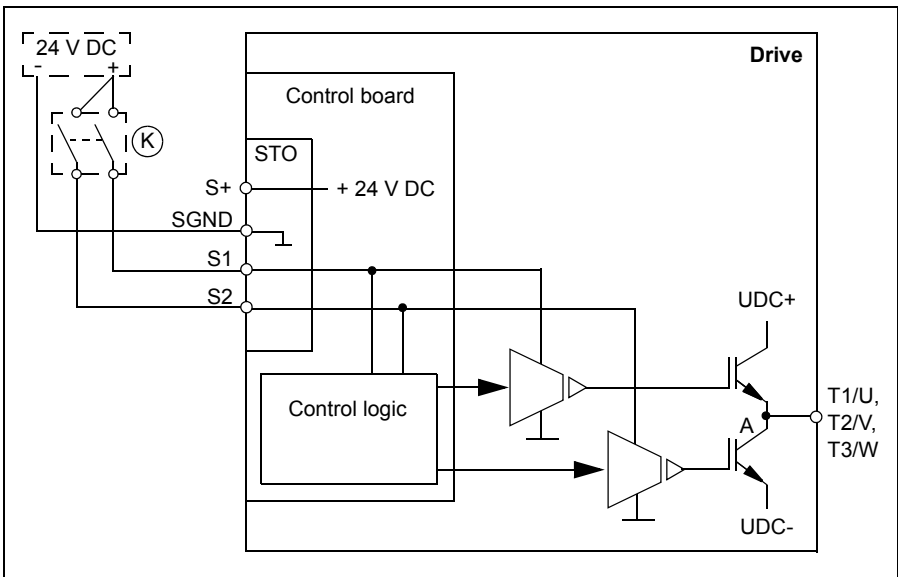

Wiring examples

An example of a Safe torque off wiring with internal +24 V DC power supply is shown below.

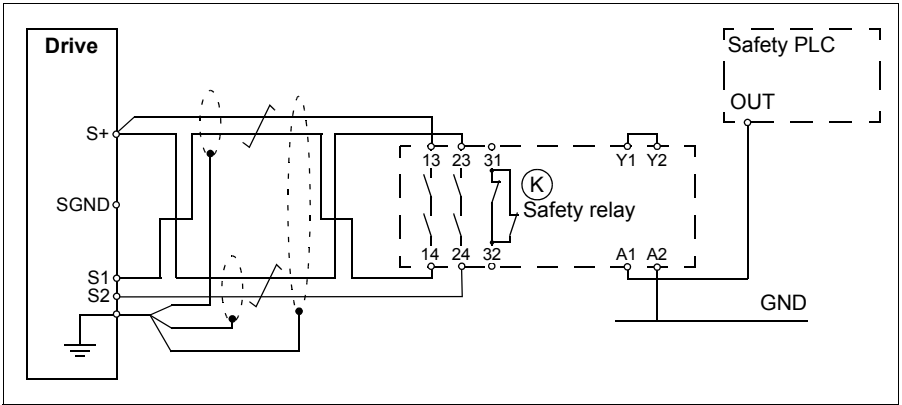

An example of a Safe torque off wiring with external +24 V DC power supply is shown below.

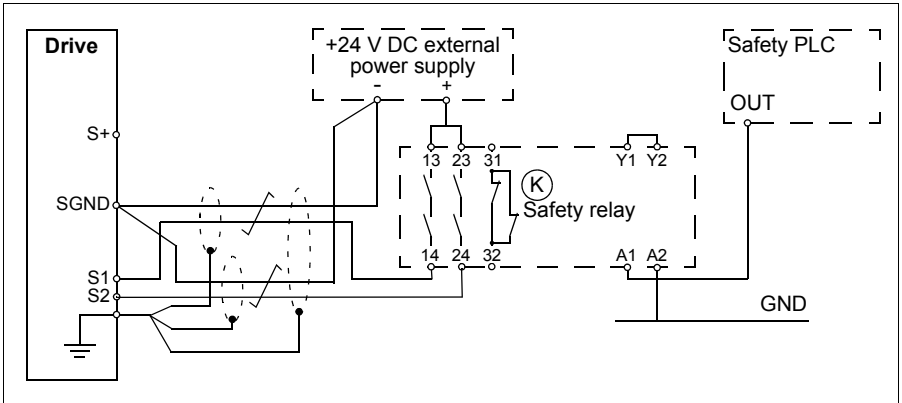

■ Activation switch

In the wiring diagram above (page 142), the activation switch has the designation (K). This represents a component such as a manually operated switch, an emergency stop push button switch, or the contacts of a safety relay or safety PLC.

- If a manually operated activation switch is used, the switch must be of a type that can be locked out to the open position.
- Inputs S1 and S2 must open/close within 200 ms of each other.

■ Cable types and lengths

- Double-shielded twisted-pair cable is recommended.
- Maximum cable length 100 m (328 ft) between activation switch (K) and drive control unit.

Note: A short-circuit in the wiring between the switch and an STO terminal causes a dangerous fault and therefore it is recommended to use a safety relay (including wiring diagnostics), or a wiring method (shield grounding, channel separation) which reduces or eliminates the risk caused by the short-circuit.

Note: The voltage at the S1 and S2 terminals of each drive must be at least 13 V DC to be interpreted as “1”. Pulse tolerance of input channels is 1 ms.

■ Grounding of protective shields

- Ground the shield in the cabling between the activation switch and the control board at the control board.
- Ground the shield in the cabling between two control boards at one control board only.

Operation principle

1. The Safe torque off activates (the activation switch is opened, or safety relay contacts open).
2. The STO inputs S1 and S2 on the drive control board de-energize.
3. The STO cuts off the control voltage from the output IGBTs.
4. The control program generates an indication as defined by parameter *31.22 STO indication run/stop*.

The parameter selects which indications are given when one or both Safe torque off (STO) signals are switched off or lost. The indications also depend on whether the drive is running or stopped when this occurs.

Note: This parameter does not affect the operation of the STO function itself. The STO function will operate regardless of the setting of this parameter: a running drive will stop upon removal of one or both STO signals, and will not start until both STO signals are restored and all faults reset.

Note: The loss of only one STO signal always generates a fault as it is interpreted as a malfunction of STO hardware or wiring.

5. The motor coasts to a stop (if running). The drive cannot restart while the activation switch or safety relay contacts are open. After the contacts close, a reset may be needed (depending on the setting of parameter *31.22*). A new start command is required to start the drive.
-

Start-up including acceptance test

To ensure the safe operation of a safety function, validation is required. The final assembler of the machine must validate the function by performing an acceptance test. The acceptance test must be performed

- at initial start-up of the safety function
- after any changes related to the safety function (circuit boards, wiring, components, settings, etc.)
- after any maintenance work related to the safety function.

■ Competence

The acceptance test of the safety function must be carried out by a competent person with adequate expertise and knowledge of the safety function as well as functional safety, as required by IEC 61508-1 clause 6. The test procedures and report must be documented and signed by this person.

■ Acceptance test reports

Signed acceptance test reports must be stored in the logbook of the machine. The report shall include documentation of start-up activities and test results, references to failure reports and resolution of failures. Any new acceptance tests performed due to changes or maintenance shall be logged into the logbook.

■ Acceptance test procedure

After wiring the Safe torque off function, validate its operation as follows.

Action	<input checked="" type="checkbox"/>
 WARNING! Follow the <i>Safety instructions</i> (page 13). If you ignore them, injury or death, or damage to the equipment can occur.	<input type="checkbox"/>
Ensure that the drive can be run and stopped freely during start-up.	<input type="checkbox"/>
Stop the drive (if running), switch the input power off and isolate the drive from the power line by a disconnecter.	<input type="checkbox"/>
Check the Safe torque off circuit connections against the wiring diagram.	<input type="checkbox"/>
Close the disconnecter and switch the power on.	<input type="checkbox"/>
<p>Test the operation of the STO function when the motor is stopped.</p> <ul style="list-style-type: none"> • Give a stop command for the drive (if running) and wait until the motor shaft is at a standstill. <p>Ensure that the drive operates as follows:</p> <ul style="list-style-type: none"> • Open the STO circuit. The drive generates an indication if one is defined for the 'stopped' state in parameter 31.22 <i>STO indication run/stop</i> (see the firmware manual). • Give a start command to verify that the STO function blocks the drive's operation. The drive displays a warning. The motor should not start. • Close the STO circuit. • Reset any active faults. Restart the drive and check that the motor runs normally. 	<input type="checkbox"/>
<p>Test the operation of the STO function when the motor is running.</p> <ul style="list-style-type: none"> • Start the drive and ensure the motor is running. • Open the STO circuit. The motor should stop. The drive generates an indication if one is defined for the 'running' state in parameter 31.22 <i>STO indication run/stop</i> (see the firmware manual). • Reset any active faults and try to start the drive. • Ensure that the motor stays at a standstill and the drive operates as described above in testing the operation when the motor is stopped. • Close the STO circuit. • Reset any active faults. Restart the drive and check that the motor runs normally. 	<input type="checkbox"/>

Action	<input checked="" type="checkbox"/>
<p>Test the operation of the failure detection of the drive. The motor can be stopped or running.</p> <ul style="list-style-type: none"> • Open the 1st channel of the STO circuit (wire coming to S1). If the motor was running, it should coast to a stop. The drive generates a <i>FA81 Safe torque off 1 loss</i> fault indication (see the firmware manual). • Give a start command to verify that the STO function blocks the inverter's operation. The motor should not start. • Close the STO circuit. • Reset any active faults. Restart the drive and check that the motor runs normally. • Open the 2nd channel of the STO circuit (wire coming to S2). If the motor was running, it should coast to a stop. The drive generates a <i>FA82 Safe torque off 2 loss</i> fault indication (see the firmware manual). • Give a start command to verify that the STO function blocks the drive's operation. The motor should not start. • Close the STO circuit. • Reset any active faults. Restart the drive and check that the motor runs normally. 	<input type="checkbox"/>
<p>Document and sign the acceptance test report which verifies that the safety function is safe and accepted for operation.</p>	<input type="checkbox"/>

Use

1. Open the activation switch, or activate the safety functionality that is wired to the STO connection.
2. The STO inputs of the drive control unit de-energize, and the drive control unit cuts off the control voltage from the drive IGBTs.
3. The control program generates an indication as defined by parameter *31.22 STO indication run/stop*.
4. The motor coasts to a stop (if running). The drive will not restart while the activation switch or safety relay contacts are open.
5. Deactivate the STO by closing the activation switch, or resetting the safety functionality that is wired to the STO connection.
6. Reset any faults before restarting.



WARNING! The Safe torque off function does not disconnect the voltage of the main and auxiliary circuits from the drive. Therefore maintenance work on electrical parts of the drive or the motor can only be carried out after isolating the drive from the main supply.



WARNING! (With permanent magnet motors or synchronous reluctance motors [SynRM] only) In case of a multiple IGBT power semiconductor failure, the drive system can produce an alignment torque which maximally rotates the motor shaft by $180/p$ degrees regardless of the activation of the Safe torque off function. p denotes the number of pole pairs.

Notes:

- If a running drive is stopped by using the Safe torque off function, the drive will cut off the motor supply voltage and the motor will coast to a stop. If this causes danger or is not otherwise acceptable, stop the drive and machinery using the appropriate stop mode before activating the Safe torque off function.
 - The Safe torque off function overrides all other functions of the drive unit.
 - The Safe torque off function is ineffective against deliberate sabotage or misuse.
 - The Safe torque off function has been designed to reduce the recognized hazardous conditions. In spite of this, it is not always possible to eliminate all potential hazards. The assembler of the machine must inform the final user about the residual risks.
 - The Safe torque off diagnostics are not available during power outages, or when the drive is only powered by the +24 V power extension module BAPO-01.
-

Maintenance

After the operation of the circuit is validated at start-up, the STO function shall be maintained by periodic proof testing. In high demand mode of operation, the maximum proof test interval is 20 years. In low demand mode of operation, the maximum proof test interval is 5 or 2 years; see section [Safety data](#) (page 150). It is assumed that all dangerous failures of the STO circuit are detected by the proof test. To perform the proof test, do the [Acceptance test procedure](#) (page 145).

Note: See also the Recommendation of Use CNB/M/11.050 (published by the European co-ordination of Notified Bodies) concerning dual-channel safety-related systems with electromechanical outputs:

- When the safety integrity requirement for the safety function is SIL 3 or PL e (cat. 3 or 4), the proof test for the function must be performed at least every month.
- When the safety integrity requirement for the safety function is SIL 2 (HFT = 1) or PL d (cat. 3), the proof test for the function must be performed at least every 12 months.

The STO function does not contain any electromechanical components.

In addition to proof testing, it is a good practice to check the operation of the function when other maintenance procedures are carried out on the machinery.

Include the Safe torque off operation test described above in the routine maintenance program of the machinery that the drive runs.

If any wiring or component change is needed after start up, or the parameters are restored, follow the test given in section [Acceptance test procedure](#) (page 145).

Use only ABB approved spare parts.

Record all maintenance and proof test activities in the machine logbook.

■ Competence

The maintenance and proof test activities of the safety function must be carried out by a competent person with adequate expertise and knowledge of the safety function as well as functional safety, as required by IEC 61508-1 clause 6.

Fault tracing

The indications given during the normal operation of the Safe torque off function are selected by parameter *31.22 STO indication run/stop*.

The diagnostics of the Safe torque off function cross-compare the status of the two STO channels. In case the channels are not in the same state, a fault reaction function is performed and the drive trips on an “STO hardware failure” fault. An attempt to use the STO in a non-redundant manner, for example activating only one channel, will trigger the same reaction.

See the drive firmware manual for the indications generated by the drive, and for details on directing fault and warning indications to an output on the control unit for external diagnostics.

Any failures of the Safe torque off function must be reported to ABB.

Safety data

The safety data for the Safe torque off function is given below.

Note: The safety data is calculated for redundant use, and does not apply if both STO channels are not used.

Frame size	SIL/SILCL	PL	SFF [%]	PFH [1/h]	PFD _{avg} [T ₁ =2a]	PFD _{avg} [T ₁ =5a]	MTTF _D ⁽¹⁾ [a]	DC ⁽²⁾ [%]	Cat.	SC	HFT	CCF	Lifetime [a]
1-phase U _N = 200...240 V													
R0	3	e	>90	8.91E-9	7.40E-5	1.85E-4	2243	≥90	3	3	1	80	20
R1	3	e	>90	8.91E-9	7.40E-5	1.85E-4	2242	≥90	3	3	1	80	20
R2	3	e	>90	8.91E-9	7.40E-5	1.85E-4	2243	≥90	3	3	1	80	20
3-phase U _N = 200...240 V													
R1	3	e	>99	8.00E-9	6.68E-5	1.67E-4	2568	≥90	3	3	1	80	20
R2	3	e	>99	8.00E-9	6.68E-5	1.67E-4	2568	≥90	3	3	1	80	20
R3	3	e	>99	8.00E-9	6.68E-5	1.67E-4	2569	≥90	3	3	1	80	20
R4	3	e	>99	8.00E-9	6.68E-5	1.67E-4	2568	≥90	3	3	1	80	20
3-phase U _N = 380...480 V													
R0	3	e	>90	8.00E-9	6.68E-5	1.67E-4	2569	≥90	3	3	1	80	20
R1	3	e	>90	8.00E-9	6.68E-5	1.67E-4	2568	≥90	3	3	1	80	20
R2	3	e	>90	8.00E-9	6.68E-5	1.67E-4	2568	≥90	3	3	1	80	20
R3	3	e	>90	8.00E-9	6.68E-5	1.67E-4	2569	≥90	3	3	1	80	20
R4	3	e	>99	8.00E-9	6.68E-5	1.67E-4	2568	≥90	3	3	1	80	20

3AXD10000320081, Rev. C

1) Use 100 years to calculate a safety loop.

2) According to EN ISO 13849-1 table E.1

- The following temperature profile is used in safety value calculations:
 - 670 on/off cycles per year with $\Delta T = 71.66 \text{ }^\circ\text{C}$ (161 $^\circ\text{F}$)
 - 1340 on/off cycles per year with $\Delta T = 61.66 \text{ }^\circ\text{C}$ (143 $^\circ\text{F}$)
 - 30 on/off cycles per year with $\Delta T = 10.0 \text{ }^\circ\text{C}$ (50 $^\circ\text{F}$)
 - 32 $^\circ\text{C}$ (90 $^\circ\text{F}$) board temperature at 2.0% of time
 - 60 $^\circ\text{C}$ (140 $^\circ\text{F}$) board temperature at 1.5% of time
 - 85 $^\circ\text{C}$ (185 $^\circ\text{F}$) board temperature at 2.3% of time
- The STO is a type A safety component as defined in IEC 61508-2.
- Relevant failure modes:
 - The STO trips spuriously (safe failure)
 - The STO does not activate when requested

A fault exclusion on the failure mode “short circuit on printed circuit board” has been made (EN ISO 13849-2, table D.5). The analysis is based on an assumption that one failure occurs at one time. No accumulated failures have been analyzed.

- STO reaction time (shortest detectable break): 1 ms
 - STO response time: 5 ms (typical), 10 ms (maximum)
 - Fault detection time: Channels in different states for longer than 200 ms
 - Fault reaction time: Fault detection time +10 ms
 - STO fault indication (parameter 31.22) delay: <500 ms
 - STO warning indication (parameter 31.22) delay: <1000 ms
 - Maximum cable length 100 m (328 ft) between activation switch (K) and drive control unit.
 - The voltage at the S1 and S2 terminals of each drive must be at least 13 V DC to be interpreted as “1”. Pulse tolerance of input channels is 1 ms.
-

■ Abbreviations

Abbr.	Reference	Description
Cat.	EN ISO 13849-1	Classification of the safety-related parts of a control system in respect of their resistance to faults and their subsequent behavior in the fault condition, and which is achieved by the structural arrangement of the parts, fault detection and/or by their reliability. The categories are: B, 1, 2, 3 and 4.
CCF	EN ISO 13849-1	Common cause failure (%)
DC	EN ISO 13849-1	Diagnostic coverage
FIT	IEC 61508	Failure in time: 1E-9 hours
HFT	IEC 61508	Hardware fault tolerance
MTTF _D	EN ISO 13849-1	Mean time to dangerous failure: (Total number of life units) / (Number of dangerous, undetected failures) during a particular measurement interval under stated conditions
PF _D _{avg}	IEC 61508	Average probability of dangerous failure on demand
PFH	IEC 61508	Average frequency of dangerous failure per hour
PL	EN ISO 13849-1	Performance level. Levels a...e correspond to SIL
SC	IEC 61508	Systematic capability
SFF	IEC 61508	Safe failure fraction (%)
SIL	IEC 61508	Safety integrity level (1...3)
SILCL	EN 62061	Maximum SIL (level 1...3) that can be claimed for a safety function or subsystem
STO	IEC/EN 61800-5-2	Safe torque off
T ₁	IEC 61508	Proof test interval. T ₁ is a parameter used to define the probabilistic failure rate (PFH or PFD) for the safety function or subsystem. Performing a proof test at a maximum interval of T ₁ is required to keep the SIL capability valid. The same interval must be followed to keep the PL capability (EN ISO 13849) valid. Note that any T ₁ values given cannot be regarded as a guarantee or warranty. See also section Maintenance (page 148).

■ Declaration of conformity

Declaration of conformity is available on the Internet. Refer to the inner back cover.

13

BTAC-02 pulse encoder interface module

Contents of this chapter

This chapter contains a description and technical data of the optional BTAC-02 pulse encoder interface module and describes how to start up the module.

Safety instructions



WARNING! Obey the instructions in [Safety instructions](#) on page 13. If you ignore them, injury or death, or damage to the equipment can occur.

Hardware description

■ Product overview

The BTAC pulse encoder interface module (option +L535) adds a digital pulse encoder interface to the drive. Use a pulse encoder, if you need accurate speed or position (angle) feedback from the motor shaft. The BTAC module supplies power to the encoder. For more information, refer to [Wiring – Encoder power supply interface](#) on page 157.

The BTAC module has the features of the BAPO-01 auxiliary power extension module. It provides back-up power to the drive. For more information, refer to [BAPO-01 power extension module](#) on page 177.

■ Layout

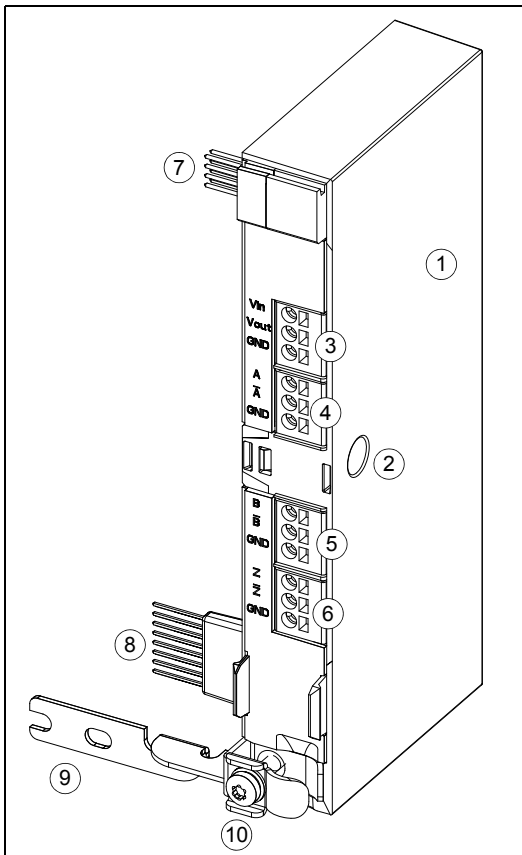

1. BTAC module
2. Locking screw hole
3. X103 connector
4. X104 connector
5. X105 connector
6. X106 connector
7. Internal X100 connector
8. Internal X102 connector
9. Grounding rail
10. Grounding screw

Mechanical installation

Refer to [To install a side option](#) on page 76.

Electrical installation



WARNING! Obey the instructions in [Safety instructions](#) on page 13. If you ignore them, injury or death, or damage to the equipment can occur.

■ Wiring – General

Connect the pulse encoder to the BTAC module with cables as specified in this table.

Cable	Max. connector size		Maximum cable length	
	4 × (2+1) double shielded twisted pair cable with individual and overall shields	2.5 mm ²	12 AWG	100 m*

* If the encoder supply voltage is less than 10 V, the maximum cable length is 50 m.

Terminal designations

The encoder user interface of the BTAC module consists of four 1×3-pin terminal blocks.

Use this table for reference when you wire the BTAC module and encoder terminals.

Identification				Description
BTAC	Encoder			
X103				
VIN	V _{cc} /PWR			External power supply input
VOUT	V _{cc} /PWR			Power supply output for the encoder
GND	0 V / GND			External power and encoder ground
X104				
A	1	A	A+	Encoder signal A + terminal
\bar{A}	$\bar{1}$	\bar{A}	A-	Encoder signal A - terminal
GND	-	-	-	Encoder ground
X105				
B	2	B	B+	Encoder signal B + terminal
\bar{B}	$\bar{2}$	\bar{B}	B-	Encoder signal B - terminal
GND	-	-	-	Encoder ground
X106				
Z	3	Z	Z+	Encoder signal Z + terminal
\bar{Z}	$\bar{3}$	\bar{Z}	Z-	Encoder signal Z - terminal
GND	-	-	-	Encoder ground.

Channels				Description												
BTAC	Encoder															
A	1	A	A+	<ul style="list-style-type: none"> • Maximum signal frequency: 200 kHz • Signal levels: <table border="1" data-bbox="453 1042 904 1166"> <thead> <tr> <th>Encoder supply voltage</th> <th>Logic "1"</th> <th>Logic "0"</th> </tr> </thead> <tbody> <tr> <td>5 V</td> <td>>2.5 V</td> <td><1.9 V</td> </tr> <tr> <td>15 V</td> <td>>7.5 V</td> <td><5.3 V</td> </tr> <tr> <td>24 V</td> <td>>12.1 V</td> <td><8.3 V</td> </tr> </tbody> </table> • Decision levels are automatically defined based on the daisy chained power supply voltage level. • Input channels are isolated from the logic and ground. • When the drive runs in the Forward direction, channel A should lead channel B by 90° (electrical). • Channel Z: One pulse per revolution (used in positioning applications only). 	Encoder supply voltage	Logic "1"	Logic "0"	5 V	>2.5 V	<1.9 V	15 V	>7.5 V	<5.3 V	24 V	>12.1 V	<8.3 V
Encoder supply voltage	Logic "1"	Logic "0"														
5 V	>2.5 V	<1.9 V														
15 V	>7.5 V	<5.3 V														
24 V	>12.1 V	<8.3 V														
\bar{A}	$\bar{1}$	\bar{A}	A-													
B	2	B	B+													
\bar{B}	$\bar{2}$	\bar{B}	B-													
Z	3	Z	Z+													
\bar{Z}	$\bar{3}$	\bar{Z}	Z-													

■ Wiring – Encoder power supply interface

Connect the encoder power supply via the BTAC module. The same power supply feeds power to the signal interface of the BTAC module. For the voltage and current rating, refer to [Encoder interface](#) on page 168.

If you use a 24 V encoder, you can use the 24 V DC power supply of the drive for the encoder and BTAC module. Make sure that you do not exceed the load capacity. Refer to [Auxiliary voltage connection](#) on page 74.

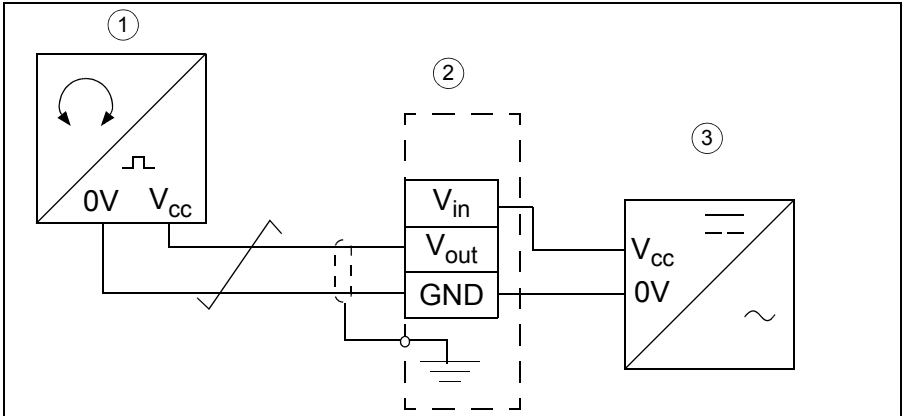

1. Encoder
2. BTAC module
3. Encoder power supply

Use the following table to determine if you can use the drive's supply. Add the missing figures and sum all: the sum value must not exceed the total load capacity of the drives' supply.

Loads with the drive's 24 V DC supply		mA
Number of digital inputs used	× 15 mA each	
BTAC-02		50 mA
Encoder current requirement =		
Total requirements for any other user connection(s) to drive's 24 V DC =		
Total (must be less than the maximum load capacity of the drive's 24 V DC supply) =		

■ Wiring – Encoder

1. Remove the connector cover.
2. Determine the encoder wiring configuration:
 - Refer to *Phasing* on page 159 to determine if the encoder has a normal pulse order – encoder channel A pulse leads channel B pulse.
 - Refer to *Encoder output types* on page 160 to determine the encoder output type.
 - For push-pull types, refer to the manufacturer's recommendation for the connection. You can use single-ended or differential output.
3. Refer to *Wiring diagrams – Push-pull type encoder output*, *Wiring diagrams – Open collector (sinking) encoder output* or *Wiring diagrams – Open emitter (sourcing) encoder output* on pages 161...164 to select the appropriate diagram, and wire the encoder.

Notes:

- Normally, ground the cable shield only at the drive end.
 - Do not route the encoder cables in parallel to power (for example, motor) cables.
4. Verify correct encoder phasing. Refer to *Phasing* on page 159.
-

Phasing

When the encoder is connected correctly, running the drive in the *Forward* (positive speed reference) direction should produce a positive encoder speed feedback.

Option A: Oscilloscope test. On incremental encoders, the two output channels, typically A and B or 1 and 2, are 90° (in phase) apart from each other. When rotated clockwise, in most encoders channel A leads channel B. To determine the leading channel, refer to the encoder documentation or use an oscilloscope.

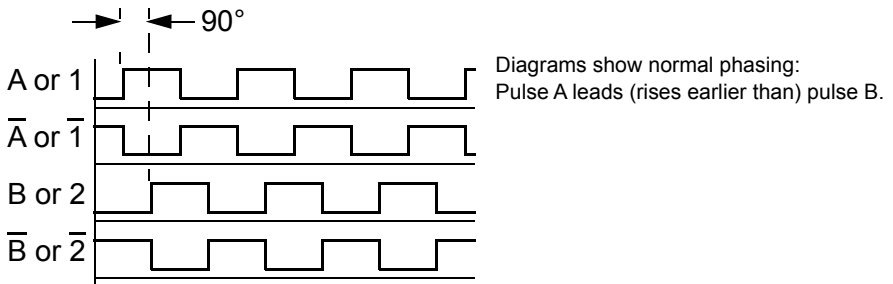

Connect the encoder output channel that leads when the drive runs *Forward* to BTAC terminal A. Connect the output channel that trails to BTAC terminal B.

Option B: Functional test. For this test:

- Temporarily, switch the drive to the scalar mode [parameter 99.04 Motor ctrl mode = 1 (SCALAR)].
- Run the drive in the forward direction.
- Verify that parameter 90.13 Enc1 revol extension increases in the positive direction.
- If not, switch the A/\bar{A} (or $1/\bar{1}$) connections.

Encoder output types

Push-pull	Open collector (sinking)	Open emitter (sourcing)
<p>V_{CC} = Encoder input power supply voltage R_L = Load resistor at encoder output channel</p>		

Wiring diagrams – Push-pull type encoder output

Diagram assumes normal pulse order in Forward rotation: Pulse A leads.

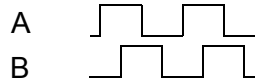

For encoders with pulse B leading, change the diagram:

- Wire encoder A and B to BTAC terminals B and A, respectively.
- Wire encoder \bar{A} and \bar{B} (if present) to BTAC terminals \bar{B} and \bar{A} , respectively.

Differential connection

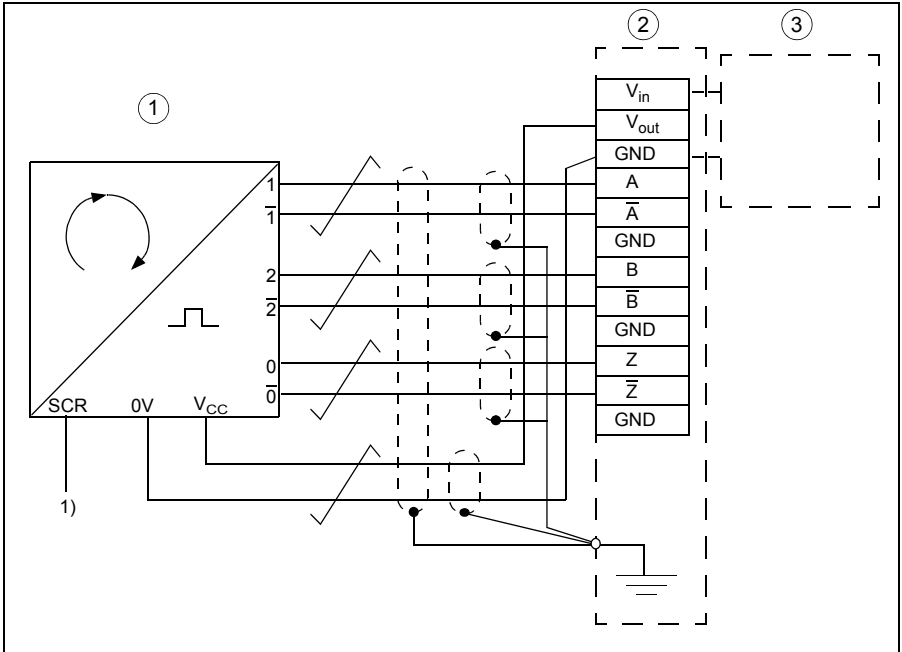

1. Encoder
2. BTAC module
3. Encoder power supply

Single-ended connection

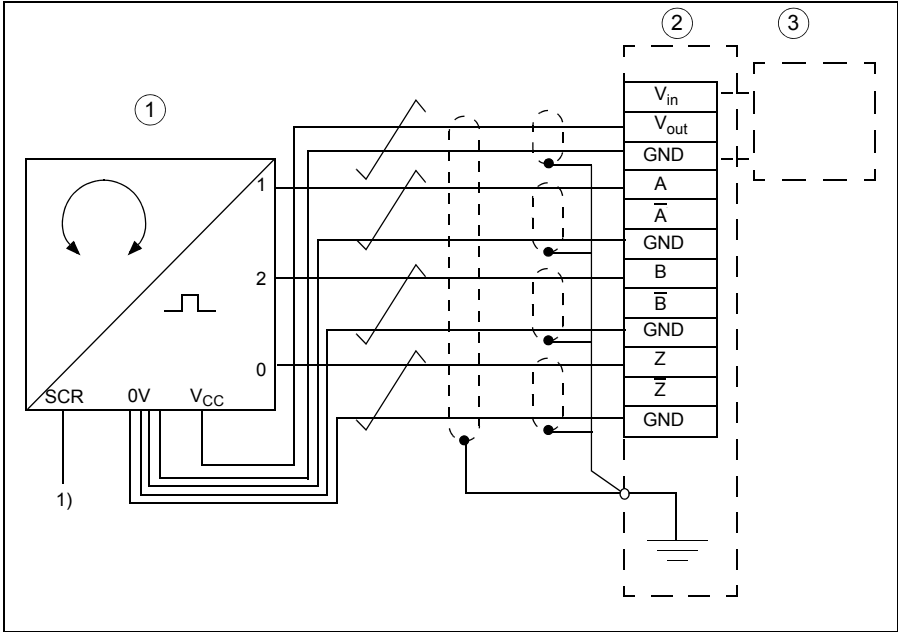

1. Encoder
2. BTAC module
3. Encoder power supply

Wiring diagrams – Open collector (sinking) encoder output

Diagram assumes normal pulse order in Forward rotation: Pulse A leads.

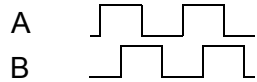

For encoders with pulse B leading, change the diagram:

- Wire encoder A and B to BTAC terminals B and A, respectively.

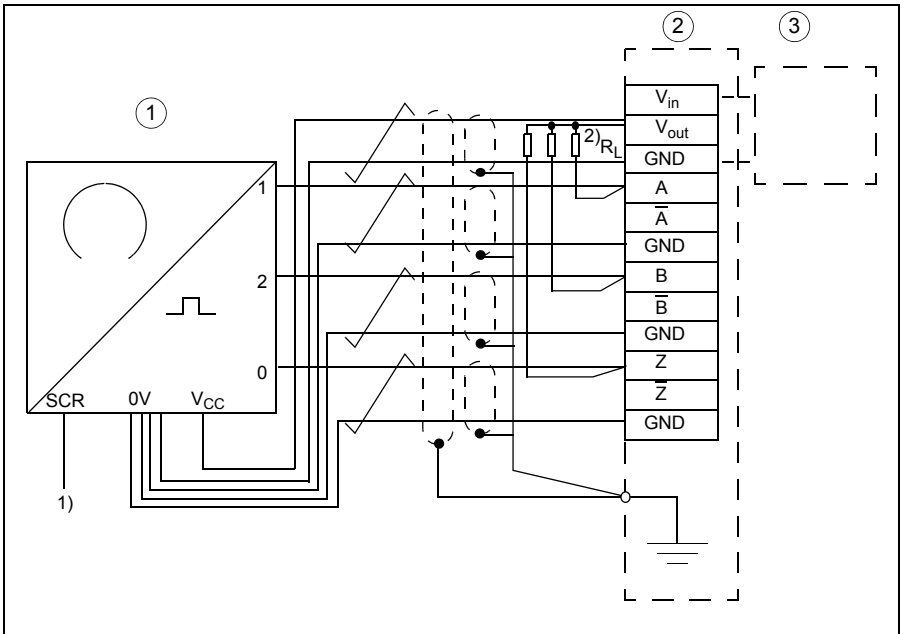

1. Encoder
2. BTAC module
3. Encoder power supply
4. Three identical resistors

The resistor size depends on the encoder power supply $V_{in} = V_{OUT}$:

$V_{in} = 30\text{ V}$	$R_L = 2.7 \dots 3.0\text{ kohm}, 0.5\text{ W}$
$V_{in} = 24\text{ V}$	$R_L = 1.8 \dots 2.2\text{ kohm}, 0.5\text{ W}$
$V_{in} = 15\text{ V}$	$R_L = 1.0 \dots 1.5\text{ kohm}, 0.5\text{ W}$
$V_{in} = 5\text{ V}$	$R_L = 390 \dots 470\text{ ohm}, 0.125\text{ W}$

Wiring diagrams – Open emitter (sourcing) encoder output

Diagram assumes normal pulse order in Forward rotation: Pulse A leads.

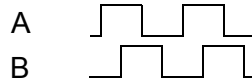

For encoders with pulse B leading, change the diagram:

- Wire encoder A and B to BTAC terminals B and A, respectively.

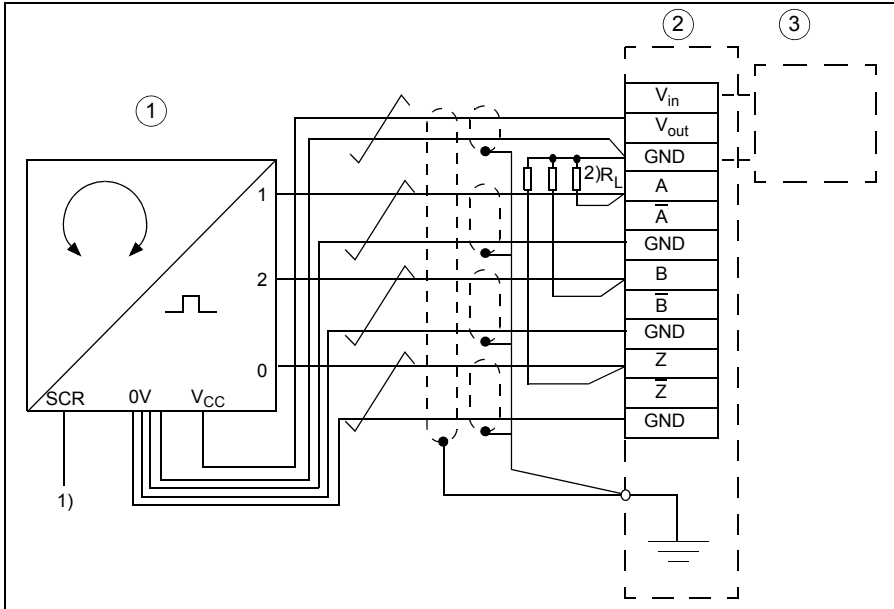

1. Encoder
2. BTAC module
3. Encoder power supply
4. Three identical resistors

The resistor size depends on the encoder power supply $V_{in} = V_{OUT}$:

$V_{in} = 30\text{ V}$	$R_L = 2.7 \dots 3.0\text{ kohm}, 0.5\text{ W}$
$V_{in} = 24\text{ V}$	$R_L = 1.8 \dots 2.2\text{ kohm}, 0.5\text{ W}$
$V_{in} = 15\text{ V}$	$R_L = 1.0 \dots 1.5\text{ kohm}, 0.5\text{ W}$
$V_{in} = 5\text{ V}$	$R_L = 390 \dots 470\text{ ohm}, 0.125\text{ W}$

Apply power

1. Turn on the input power to the drive.
2. Continue with *Start-up* on page 165.

Start-up

To configure the operation of the BTAC module:

1. Power up the drive.
2. Set group 90 *Feedback selection*, 91 *Encoder adapter settings* and 92 *These parameters display the configuration of the encoder interface modules. Encoder configuration* parameters described on pages 165...166.

■ Feedback selection

Use these parameters to select feedback or display feedback from the encoder.

No.	Name/Value	Description	Def/FbEq16/32
90 Feedback selection			
90.01	Motor speed for control	Displays the estimated or measured motor speed that is used for motor control, ie. final motor speed feedback selected by parameter 90.41 Motor feedback selection and filtered by 90.42 Motor speed filter time. This parameter is read-only.	-
	-32768...32767	Motor speed used for control.	1=1 rpm/ 100=1 rpm
90.02	Motor position	Displays the motor position (within one revolution) received from the source selected by parameter 90.41 Motor feedback selection.	
	0 ... 1 rev	Motor position.	32767=1 rev/ 100000000=1 rev
90.10	Enc1 speed	Displays encoder 1 speed in rpm. This parameter is read-only.	-
	-32768...32767	Encoder 1 speed.	1=1 rpm/ 100=1 rpm
90.11	Enc1 position	Displays the actual position of encoder 1 within one revolution. This parameter is read-only.	-
	0 ... 1 rev	Encoder 1 position within one revolution.	32767=1 rev/ 100000000=1 rev
90.13	Enc1 revol extension	Displays the revolution counter extension. The counter is incremented when encoder position wraps around in the positive direction, and decremented in the negative direction. The parameter is effective only if the position is absolute. The parameter value is updated for both single-turn and multiturn encoders. This parameter is read-only.	na/1=1

No.	Name/Value	Description	Def/FbEq16/32
90.41	Motor feedback sel	Selects the source of motor speed and motor position used as feedbacks for speed control and motor model.	estimate
	estimate	A calculated speed estimate	0
	Encoder 1	Actual speed measured by encoder 1.	1
90.42	Motor speed filt time	Defines a filter time for motor speed feedback used for control.	3 ms
	0 ... 10000 ms	Motor speed filter time.	1=1 ms/1=1 ms
90.45	Motor feedback fault	Selects how the drive reacts to loss of measured motor feedback.	Fault
	Fault	Drive trips on a 7301 Motor speed feedback fault.	0
	Warning	Drive generates a A7B0 Motor speed feedback warning and continues operation using estimated feedbacks. Note: Before using this setting, test the stability of the speed control loop with estimated feedback by running the drive on estimated feedback (see 90.41 Motor feedback sel).	1
90.46	Force open loop	Defines the speed feedback used for motor control.	No
	No	The motor model uses the feedback selected by 90.41 Motor feedback sel.	0
	Yes	The motor model uses the calculated speed estimate (regardless of the setting of 90.41 Motor feedback sel, which in this case only selects the source of feedback for the speed controller).	1
90.47	Enable motor encoder drift detection	Enables motor encoder drift detection	Yes
	No	Does not generate an error if encoder drift is detected.	0
	Yes	Generates fault 7301 Motor speed feedback if encoder drift is detected.	1

Encoder adapter settings

These parameters display the configuration of the encoder interface modules.

No.	Name/Value	Description	Def/FbEq16/32
91 Enc adapter settings			
91.10	Enc par refresh	Validates any changed encoder interface module parameters. This is needed for any parameter changes in groups 90...92 to take effect. After refreshing, the value reverts automatically to Done. Note: The parameter cannot be changed while the drive is running.	Done
	Done	Refreshing done.	0
	Configure	Refreshing.	1

Encoder configuration

This parameter group selects the settings for the encoder.

No.	Name/Value	Description	Def/FbEq16/32
92 Encoder 1 configuration			
92.10	Pulses/rev	Defines the TTL or HTL pulse number per revolution.	32
	0...65535		1=1

Diagnostics

With parameter 90.45 Motor feedback fault, you can select how the drive reacts when it detects that the encoder signal is lost.

- 90.45 = 0 (Fault) – The drive generates a fault (7301 Motor speed feedback), and the motor coasts to a stop.
- 90.45 = 1 (Warning) – The drive generates a warning (A7B0 Motor speed feedback) and continues operation using estimated feedbacks.

If the drive generates this fault or warning:

Code (hex)	Fault/Warning	Cause
7301	Motor speed feedback	No motor speed feedback is received.
	4	Drift detected. Check for slippage between encoder and motor.
	3FC	Incorrect motor feedback configuration
	3FD	Incorrect motor speed
A7B0	Motor speed feedback	No motor speed feedback is received
	4	Encoder drift detected. Check for slippage between encoder and motor.
	3FC	Incorrect motor feedback configuration
	3FD	Incorrect motor speed

Technical data

■ Encoder interface

The encoder user interface is isolated with reinforced insulation from the DC-potential.

Encoder type

- Incremental, TTL/HTL encoders
- Differential, single-ended, open collector, and open emitter encoder outputs (refer to [Encoder output types](#) on page 160)
- Three channels A, B and Z
- Maximum pulse frequency: 200 kHz
- Encoder power supply range: 5...30 V

For the input signal levels, refer to [Terminal designations](#) on page 156.

Encoder interface connectors

Four 3-pin (1×3) spring-clamp type terminal blocks, tin plated, 2.5 mm² wire size, pitch 5.0 mm.

For the terminals, refer to [Terminal designations](#) on page 156.

Cable

The maximum permitted cable length is 100 m.

Encoder and BTAC module power supply

- 50 mA (BTAC) + encoder current consumption (refer to the encoder data sheet)
- Voltage: 5...30 V DC (Depends on the encoder. Refer to the encoder data sheet.)

■ Back-up power supply for the drive

Refer to [Auxiliary voltage connection](#) on page 74.

■ Internal connectors

Connector X102 provides encoder interface signals to the drive control board.

Connector X102 data: 1×8 pin header, pitch 2.54 mm, height 33.53 mm.

Connector X100 serves as power supply interface between the BTAC module and the drive's control board. It provides back-up power supply in main power loss situations.

Connector X100 data: 2×4 pin header, pitch 2.54 mm, height 15.75 mm.

■ Dimensions

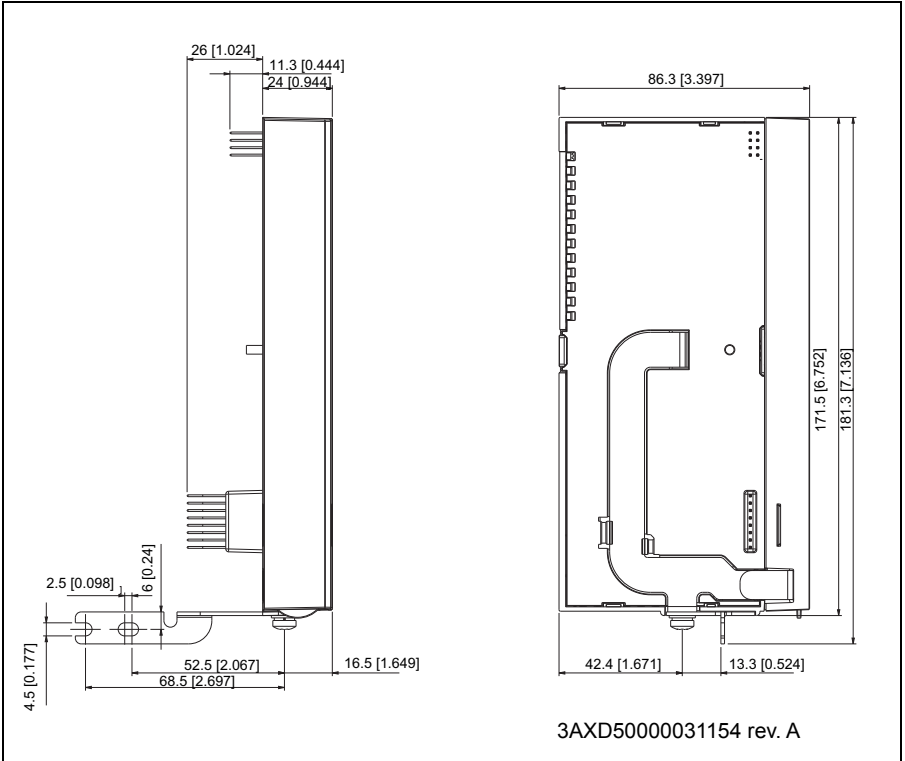

14

BREL-01 relay output extension module

Contents of this chapter

This chapter contains a description and technical data of the optional BREL-01 relay output extension module.

Safety instructions



WARNING! Obey the instructions in [Safety instructions](#) on page 13. If you ignore them, injury or death, or damage to the equipment can occur.

Hardware description

■ Product overview

BREL-01 relay output extension module (option +L511) adds four relay outputs to the drive.

■ Layout

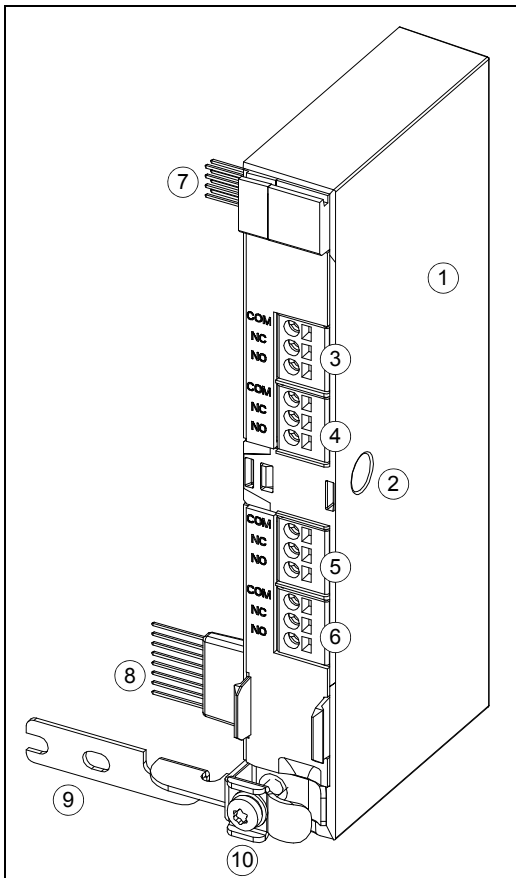

1. BREL module
2. Locking screw hole
3. X103 connector
4. X104 connector
5. X105 connector
6. X106 connector
7. Internal X100 connector
8. Internal X102 connector
9. Grounding rail
10. Grounding screw

Mechanical installation

Refer to [To install a side option](#) on page 76.

Electrical installation



WARNING! Obey the instructions in [Safety instructions](#) on page 13. If you ignore them, injury or death, or damage to the equipment can occur.

Terminal designations

The relay interface of the BREL module consists of four 1×3-pin terminal blocks.

Use this table for reference when you wire the terminals.

Identification		Description	
X103			Output relays 2-5: • Max. switching voltage: 250 V AC / 30 V DC • Max. switching current: 2 A Galvanically isolated.
1	COM		
2	NC		
3	NO		
X104			Inductive loads (such as contactor coils): Protect the relay contacts as recommended in Protecting the contacts of relay outputs on page 59.
1	COM		
2	NC		
3	NO		
X105			
1	COM		
2	NC		
3	NO		
X106			
1	COM		
2	NC		
3	NO		

Wiring

Use 0.5 to 2.5 mm² (20 to 14 AWG) cable with an appropriate voltage rating for digital signals.

Refer to [Terminal designations](#) on page 173 and connect control wires to the BREL module.

Apply power

1. Turn on the input power to the drive.
2. Continue with [Start-up](#) on page 174.

Start-up

To configure the operation of the relays added with the BREL module:

1. Power up the drive.
2. Set the parameter 15.01 Extension module type to 5 (BREL).
3. Use the control panel on the drive and set the parameters for relay outputs 2 to 5 in 15 I/O extension module. Refer to *ACS380 Firmware manual* (3AXD50000029275 [English]) for parameter descriptions.

Configuration parameters

The configuration parameters of the BREL module are in group 15 I/O extension module.

No.	Name/Value	Description	Def/FbEq16/32
15 I/O extension module			
15.01	Extension module type	Sets the connected side-mounted extension module.	None
	BREL	Basenut relay extension module	5
15.02	Detected extension module	I/O extension module detected on the drive.	None
	BREL	Basenut relay extension module	5
15.04	RO status	Status of the relay outputs.	1=1
	Bit 0 RO2	Relay 2 output status. 1 = open / 0 = closed	
	Bit 1 RO3	Relay 3 output status. 1 = open / 0 = closed	
	Bit 2 RO4	Relay 4 output status. 1 = open / 0 = closed	
	Bit 3 RO5	Relay 5 output status. 1 = open / 0 = closed	
15.05	RO force selection	Selection of relay outputs for forcing.	1=1
	Bit 0 RO2	Relay 2 output status. 1 = selected to force / 0 = normal	
	Bit 1 RO3	Relay 3 output status. 1 = selected to force / 0 = normal	
	Bit 2 RO4	Relay 4 output status. 1 = selected to force / 0 = normal	
	Bit 3 RO5	Relay 5 output status. 1 = selected to force / 0 = normal	
15.06	RO forced data	Relay output forcing.	1=1
	Bit 0 RO2	Relay 2 output status. 1 = open / 0 = closed	
	Bit 1 RO3	Relay 3 output status. 1 = open / 0 = closed	
	Bit 2 RO4	Relay 4 output status. 1 = open / 0 = closed	
	Bit 3 RO5	Relay 5 output status. 1 = open / 0 = closed	
15.07	RO2 source	Relay output 2 source selection.	
		Relay output 2 is open.	0
		Relay output 2 is closed	1
		For complete parameter list, refer to <i>ACS380 Firmware manual</i> (3AXD50000029275 [English])	...

No.	Name/Value	Description	Def/FbEq16/32
15.08	RO2 ON delay	Sets the activation delay for relay output 2.	0.0 s
	0.0...3000.0 s	Activation delay for relay output 2.	10 = 1 s
15.09	RO2 OFF delay	Sets the deactivation delay for relay output 2.	0.0 s
	0.0...3000.0 s	Deactivation delay for relay output 2.	10 = 1 s
15.10	RO3 source	Relay output 3 source selection.	
		Relay output 3 is open.	0
		Relay output 3 is closed	1
		For complete parameter list, refer to <i>ACS380 Firmware manual</i> (3AXD50000029275 [English])	...
15.11	RO3 ON delay	Sets the activation delay for relay output 3.	0.0 s
	0.0...3000.0 s	Activation delay for relay output 3.	10 = 1 s
15.12	RO3 OFF delay	Sets the deactivation delay for relay output 3.	0.0 s
	0.0...3000.0 s	Deactivation delay for relay output 3.	10 = 1 s
15.13	RO4 source	Relay output 4 source selection.	
		Relay output 4 is open.	0
		Relay output 4 is closed	1
		For complete parameter list, refer to <i>ACS380 Firmware manual</i> (3AXD50000029275 [English])	...
15.14	RO4 ON delay	Sets the activation delay for relay output 4.	0.0 s
	0.0...3000.0 s	Activation delay for relay output 4.	10 = 1 s
15.15	RO4 OFF delay	Sets the deactivation delay for relay output 4.	0.0 s
	0.0...3000.0 s	Deactivation delay for relay output 4.	10 = 1 s
15.16	RO5 source	Relay output 5 source selection.	
		Relay output 5 is open.	0
		Relay output 5 is closed	1
		For complete parameter list, refer to <i>ACS380 Firmware manual</i> (3AXD50000029275 [English])	...
15.17	RO5 ON delay	Sets the activation delay for relay output 5.	0.0 s
	0.0...3000.0 s	Activation delay for relay output 5.	10 = 1 s
15.18	RO5 OFF delay	Sets the deactivation delay for relay output 5.	0.0 s
	0.0...3000.0 s	Deactivation delay for relay output 5.	10 = 1 s

Technical data

External connectors

Four 3-pin (1×3) spring-clamp type terminal blocks, tin plated, 2.5 mm² wire size, pitch 5.0 mm.

For the terminal markings, refer to *Terminal designations* on page 173.

Internal connectors

Connector X102 provides relay control signals from the control board:
1×8 pin header, pitch 2.54 mm, height 33.53 mm.

Connector X100 is not in use in BREL:
2×4 pin header, pitch 2.54 mm, height 15.75 mm.

Dimensions

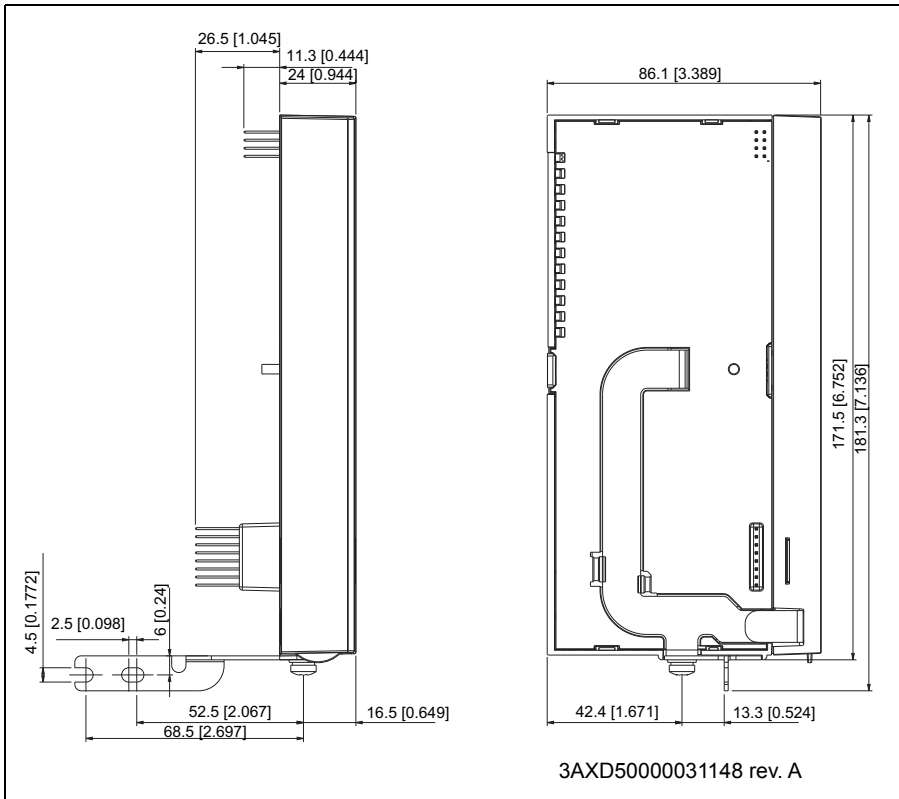

15

BAPO-01 power extension module

Contents of this chapter

This chapter contains a description and technical data of the optional BAPO-01 auxiliary power extension module. The chapter also contains references to the relevant other content elsewhere in the manual.

Safety instructions



WARNING! Obey the instructions in [Safety instructions](#) on page 13. If you ignore them, injury or death, or damage to the equipment can occur.

Hardware description

■ Product overview

The BAPO-01 auxiliary power extension module (option +L534) enables the use of an external auxiliary power supply with the drive. You need an external auxiliary power supply to keep the drive on during a power outage. Connect the auxiliary voltage supply to the +24V and DGND terminals on the drive.

If you change the drive parameters when the control board is energized with the BAPO module, force parameter saving with parameter 96.07 PARAM SAVE by setting the value to (1) SAVE. Otherwise, changed data will not be saved.

■ Layout

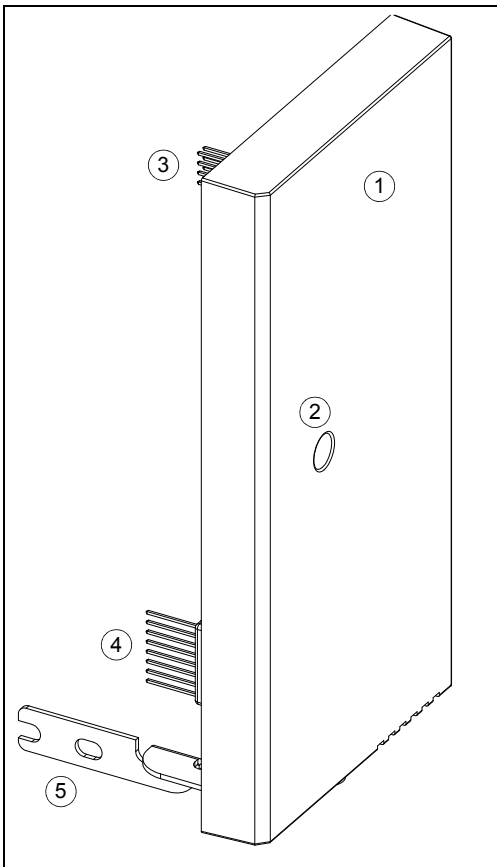

1. BAPO module
2. Locking screw hole
3. Internal X100 connector
4. Internal X102 connector
5. Grounding rail

Mechanical installation

Refer to [To install a side option](#) on page 76.

Electrical installation

Connect the auxiliary voltage supply to the +24V and DGND terminals on the drive. Refer to [Auxiliary voltage connection](#) on page 74. The BAPO module has internal connections to provide back-up power to the control board (I/O, fieldbus).

Start-up

To configure the BAPO module:

1. Power up the drive.
 2. Set the parameter 95.04 Control board supply to 1 (External 24V).
-

Technical data

■ Voltage and current rating for the auxiliary power supply

Refer to [Auxiliary voltage connection](#) on page 74.

■ Power loss

Power losses with maximum load 4 W.

■ Dimensions

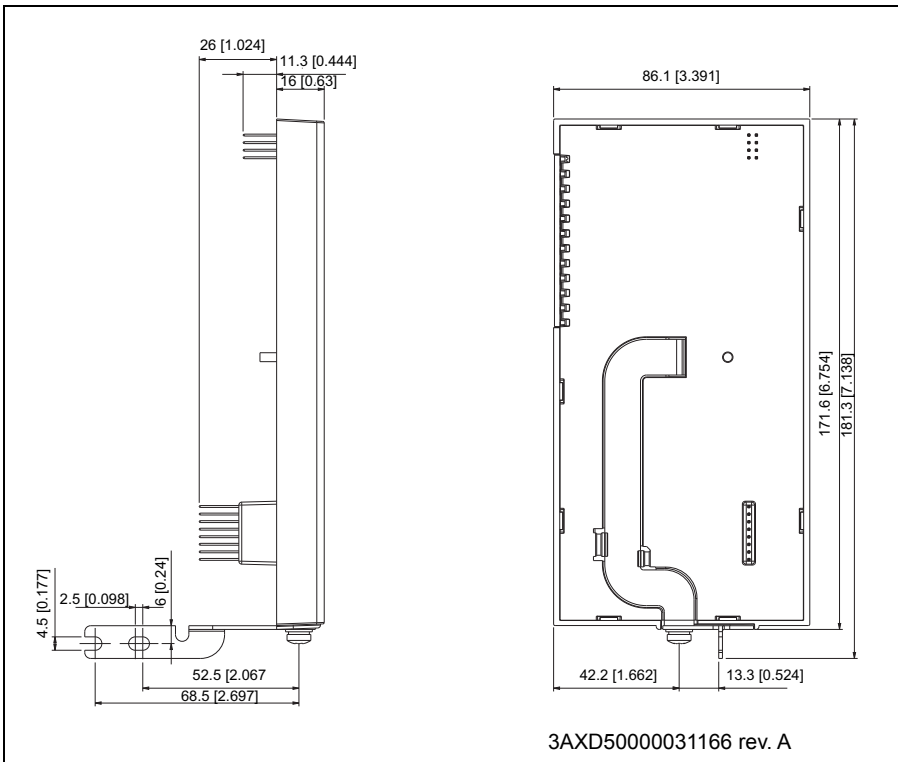

16

BIO-01 I/O extension module

Contents of this chapter

This chapter contains a description and technical data of the optional BIO-01 I/O extension module. The chapter also contains references to the relevant other content elsewhere in the manual.

Safety instructions



WARNING! Obey the instructions in [Safety instructions](#) on page 13. If you ignore them, injury or death, or damage to the equipment can occur.

Hardware description

■ Product overview

The BIO-01 front option module (Option +L515) is an I/O extension module to be used with fieldbus. The BIO-01 option module is installed between the drive and the fieldbus module. The BIO-01 has three additional digital inputs (DI3, DI4 and DI5), one analog input (AI1) and one digital output (DO1) that is referred as DIO1 in the firmware (but works only in output mode). You can use DI4 and DI5 as frequency inputs and DO1 as a frequency output.

BIO-01 terminal block is removable and uses spring clamps for assembly.

■ Layout

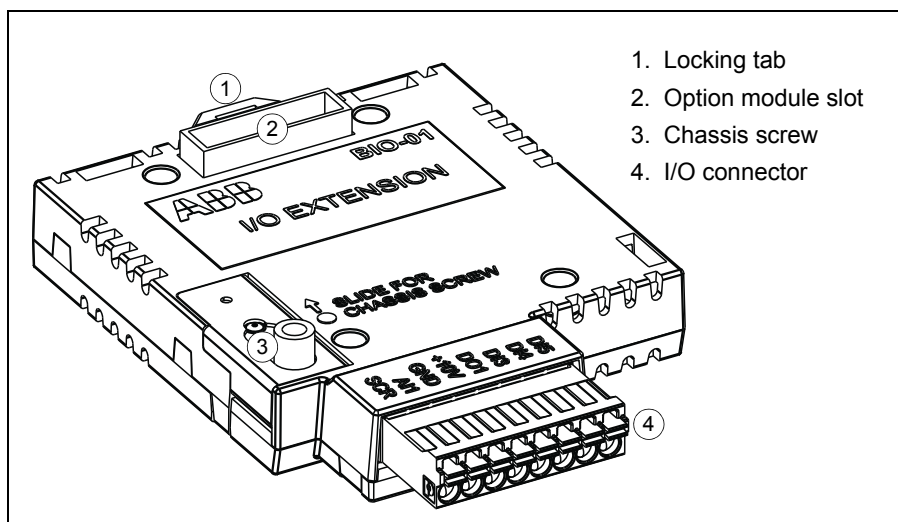

Mechanical installation

Refer to [To install a front option](#) on page 75.

Before you install the BIO-01 option module, make sure that the chassis screw slider is in the top position. After the option module is installed, tighten the chassis screw and move the slider to the bottom position.

The BIO-01 option module kit comes with a higher cable clamp plate. Use this cable clamp plate to ground the wires that connect to the BIO-01 option module.

Electrical installation

Refer to [Electrical installation](#) on page 61. If you configure the inputs, set up the wiring accordingly. The BIO-01 module has removable spring clamp terminals. Use ferrules on the multistranded cables before assembly.

Sample wiring with the ABB standard macro:

Terminals External sample connection	Description	Base unit	Internal connection	
Aux. voltage output and prog. digital input				
+24V	Aux. output +24 V DC, max. 200 mA	X		
DGND	Aux. voltage output common	X		
DCOM	Digital input common for all	X		
DI1	Stop (0)/Start (1)	X		
DI2	Forward (0)/Reverse (1)	X		
Digital and analog I/O extension BIO-01				
DI3	Constant frequency/speed selection			
DI4	Constant frequency/speed selection			
DI5	Ramp set 1 (0)/Ramp set 2 (1)			
DO1	Not configured			
AI1	Output frequency/speed ref: 0...10 V			
+10V	Ref. voltage +10 V DC (max. 10 mA)			
GND	Analog circuit common / DO common			
SCR	Signal cable shield / DO screen			
Safe torque off (STO)				
SGND	Safe torque off. Factory connection.	X		
IN1	Both circuits must be closed for the drive to start.	X		
IN2		X		
OUT1		X		

Start-up

The BIO-01 module is automatically identified by the drive firmware. To configure the inputs refer to the *ACS380 firmware manual* (3AXD50000029275 [English]).

Technical data

■ Control connection data

For BIO-01 electrical data, refer to [Technical data](#) on page 87.

■ Dimensions

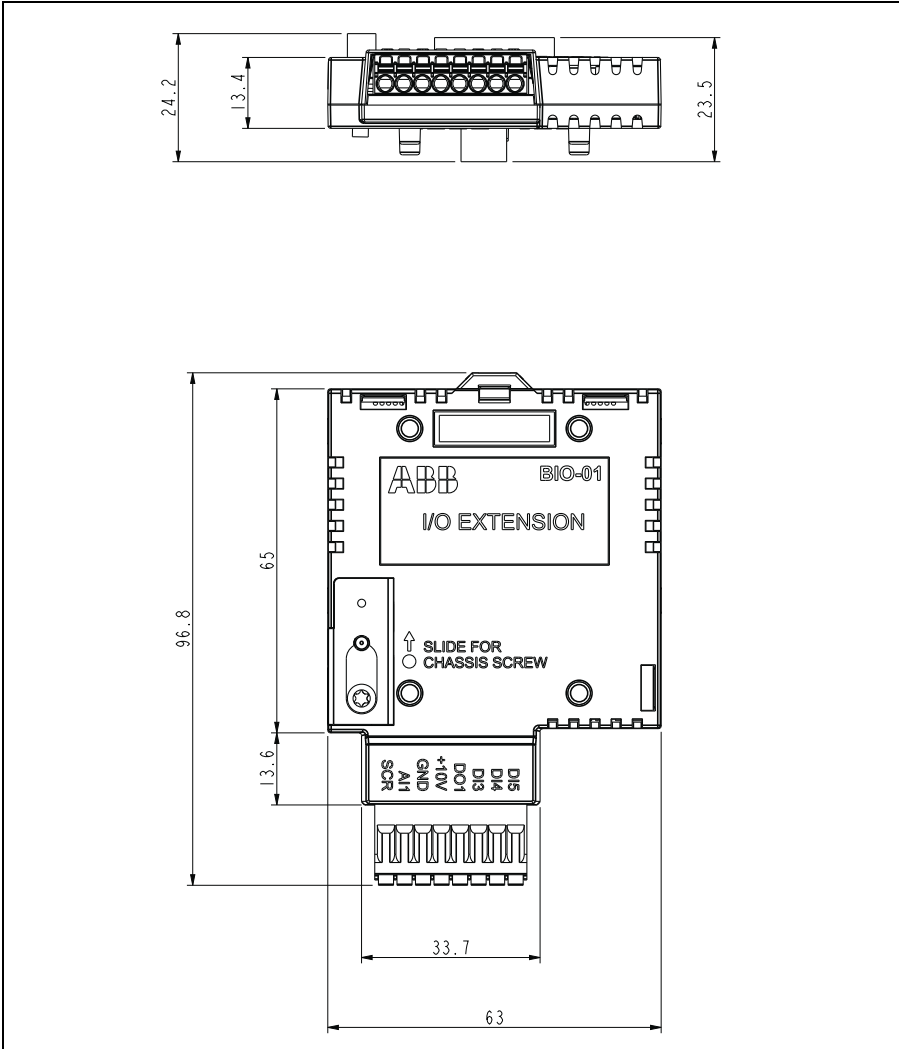

Note! BIO-01 is supplied with a high cover part (part no 3AXD50000190188) that increases the drive depth by 15 mm (0.6 in).

Further information

Product and service inquiries

Address any inquiries about the product to your local ABB representative, quoting the type designation and serial number of the unit in question. A listing of ABB sales, support and service contacts can be found by navigating to abb.com/searchchannels.

Product training

For information on ABB product training, navigate to new.abb.com/service/training.

Providing feedback on ABB Drives manuals

Your comments on our manuals are welcome. Navigate to new.abb.com/drives/manuals-feedback-form.

Document library on the Internet

You can find manuals and other product documents in PDF format on the Internet at abb.com/drives/documents.



3AXD5000029274D